

SJC

Institute

Strategic Cost Management

CMA FINAL

DIVYA JADI BOOTI



CA SATISH JALAN

CMA MOCK TEST SANGRAM

Attention CMA Students

Raise your Confidence level for upcoming CMA Exam
by availing our **MOCK TEST SERIES**

STOP GIVING ATTEMPTS

PASS CMA EXAM IN ONE SHOT



CA Satish Jalan

After identifying the root causes of exam failure and repeated attempts and having surveyed with over **25,000+ students**, and having implemented it with **500+ students**, we have devised a carefully planned system which is known among the CMA students as - **Mock Test Sangram Series**.

WHY CHOOSE US?

- Enhance your passing chance from 10% to 90%
- Get the confidence that the entire question paper seems like a normal class test.
- Say Goodbye to Repeated Attempts!

This is how MOCK TEST Sangram will help you:

- Revisions with Targets
- Remove Nervousness and Anxiety
- Time Management
- Understanding the Question Pattern
- Answer sheet with proper feedback
- Know your Strengths & weakness

Pass your CMA Exam in the next attempt itself

By registering with us ALL SUBJECTS TESTS, get a bonus of :

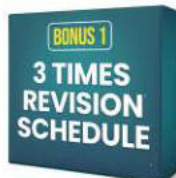

Three Revisions with targets will help you to increase your grip

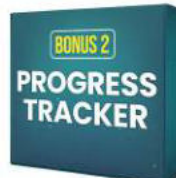

Our Broad Progress Tracker is a Chart - delivered at your door step



Live Strategy Sessions to approach the exams with confidence

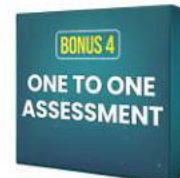

One-to-one preparation Assessment - To know where and why you are unable to move ahead, in spite of giving your best.

3 PART TEST (Phase 1) & 1 FULL TEST (Phase 2)

CMA FINAL

SCM - SFM COMBO

1.5 View for 2 years

SCM - ₹ 10,500/-

SFM - ₹ 10,500/-

Combo - ₹ 18,500/-

Save ₹ 2500/-

- ◆ Activate anytime
- ◆ With Hard Copy of Books



Enroll Now



CA Satish Jalan

☎ 8100 11 2222

🌐 www.sjc.co.in



CMA FINAL GROUP 4

SPMBV

 **Mode - GD**

Price Pre Booking at
10000/- **Rs 8000/-**

CA Satish Jalan

Call us : 8100-11-2222

sjcinstitute.com



Strategic Cost Management

CMA FINAL

DIVYA JADI BOOTI

Name :

Address :

.....

.....

Contact No.

S J C Registration No. :

“Live as if you were to die tomorrow. Learn as if you were to live forever.”

Mahatma Gandhi

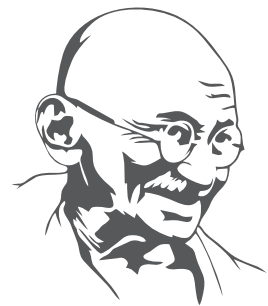

© SJC Institute LLP

This book shall not be reproduced or shared by photocopying, recording, or otherwise by any unauthorised person without prior written permission from the publisher.



Our Aim

is to Gift CA/CMAs to Every Family

Welcome Aboard To Our Goal



Content

SL NO.	Module Name	Chapter Name	Page No	Weight	
SECTION A: Strategic Cost Management for Decision Making					
1	Introduction to Strategic Cost Management	1.1	Concepts of Strategic Cost Management in different stages of Value Chain	2	
		1.2	Value Chain Analysis and Value Engineering - Business Process Reengineering	8	
		1.3	Cost Control and Cost Reduction – Contemporary Techniques	9	
2	Quality Cost Management	2.1	Total Quality Management	10	
		2.2	Lean Accounting	18	
		2.3	Cost of Quality	24	
3	Decision Making Techniques	3.1	Decisions Involving Alternative Choices	27	
		3.2	Relevant Cost Analysis	37	
		3.3	Asset Life Cycle Costing	44	
		3.4	Transfer Pricing	45	
		3.5	Decision Making using Probability	58	
		3.6	Pricing Decisions and Strategies	55	
4	Activity Based Management and Just in Time (JIT)	4.1	Activity Based Costing	63	
		4.2	Just-in-Time (JIT)	65	
		4.3	Throughput Accounting	66	
5	Evaluating Performance - Variance Analyses			68	
SECTION B: Quantitative Techniques in Decision Making					
6	Linear Programming			82	
7	Transportation			89	
8	Assignment			94	
9	Game Theory			103	
10	Simulation			110	
11	Network Analysis – PERT, CPM			116	
12	Learning Curve			125	
13	Business Application of Maxima and Minima			132	
14	Business Forecasting Models (Time Series and Regression Analysis)			136	
15	Introduction to Tools for Data Analytics			141	
16	Multiple Choice Questions			145	

Introduction to Strategic Cost Management

1.1

Concepts of Strategic Cost Management in different stages of Value Chain

1.2

Value Chain Analysis and Value Engineering - Business Process Reengineering

1.3

Cost Control and Cost Reduction – Contemporary Techniques

Chapter 1.1

Concepts of Strategic Cost Management in Different Stages of Value Chain

Q1

June'23 MTP Set 1

'Value chain is a powerful tool for disaggregating a company into its strategically relevant activities' - **Explain** the elements of the value chain. [4]

<p>Reference</p> <p>Elements of Value Chain</p>	<p>What's New</p>
---	--------------------------

Answer

Developed by **Michael Porter in 1985** and used throughout the world, the value chain is a **powerful tool for disaggregating a company** into its strategically relevant activities in order to focus on the sources of competitive advantage, that is, the specific activities that result in lower costs or higher prices. A company's value chain is typically **part of a larger value system** that includes companies either upstream (suppliers) or downstream (distribution channels), or both. This perspective about how value is created forces managers to consider and see each activity not just as a cost, but as a step that has to add some increment of value to the finished product or service. **Manufacturing companies** create value by acquiring raw materials and using them to produce something useful. **Retailers** bring together a range of products and present them in a way that is convenient to customers, sometimes supported by services such as trial rooms or personal shopper advice and **insurance companies** offer policies to customers that are underwritten by larger re-insurance policies. Here, they are packaging these larger policies in a customer-friendly way, and distributing them to a mass audience. In other words, the value that is created and captured by a company as reduced by the costs incurred is the profit margin. Expressed as a formula the equation would read as:

Value Created and Captured – Cost of Creating that Value = Profit Margin

The more value an organisation creates, the more profitable it is likely to be. As more and more value is provided to the customers, competitive advantage creeps in. Understanding how a company creates value, and looking for ways to add more value, are critical elements in developing a competitive strategy. Thus, the value chain is a set of activities that an organ-

isation carries out to create value for its customers. Porter proposed a general-purpose value chain that companies can use to examine all of their activities, and see how they are connected. The way in which value chain activities are performed determines costs and affects profits.

Elements in Porter's Value Chain

Rather than looking at departments or accounting cost types, Porter's Value Chain focuses on systems, and how inputs are changed into the outputs purchased by consumers. Using this viewpoint, Porter described a chain of activities common to all businesses, and he divided them into primary and support activities, as shown below.

Primary Activities: Primary activities relate directly to the physical creation, sale, maintenance and support of a product or service. They consist of the following:

- **Inbound Logistics:** These are all the processes related to receiving, storing, and distributing the inputs internally. The supplier relationships are a key factor in creating value here.
- **Operations:** These are the transformation activities that change inputs into outputs that are sold to customers. Here, operational systems create value.
- **Outbound Logistics:** These activities deliver the product or service to the customer. These are the things like collection, storage, and distributing the outputs. They may be internal or external to the organisation.
- **Marketing and Sales:** These are the processes that are used to persuade clients to purchase from the firm instead of its competitors. The benefits being offered, and how well they are communicated to the customers, are sources of value here.
- **Service:** These are the activities related to maintaining the value of the product or service to customers, once it has been purchased.

Support Activities:

Support activities support the primary functions stated above. Each support, or secondary, activity can play a role in each primary activity. For example, procurement supports operations with certain activities, but it also supports marketing and sales with other activities.

- **Procurement (Purchasing):** This is what the organisation does to get the resources it needs to operate. This includes finding vendors and negotiating best prices.
- **Human Resource Management:** This is how well a company recruits, hires, trains, motivates, rewards, and retains its workers. People are a significant source of value, so businesses can create a clear advantage with good HR practices.
- **Technological Development:** These activities relate to managing and processing information, as well as protecting a company's knowledge base. Minimizing information technology costs, staying current with technological advances, and maintaining technical excellence are sources of value creation.
- **Infrastructure:** These are a company's support systems, and the functions that allow it to maintain daily operations. Accounting, legal, administrative, and general management are examples of necessary infrastructure that businesses can use to their advantage.

Q2

June'23 MTP Set 1

“Value chain analysis help an organization in gaining competitive advantage” – **Explain** the validity of the above statement in a dynamic business world. [2]

Reference	What's New
Value Chain Analysis	

Answer

Value chain analysis (VCA) is a process where a firm identifies its **primary and support activities** that add value to its final product and then analyse these activities to reduce costs or increase differentiation. Value chain analysis relies on the **basic economic principle of advantage** - companies are best served by operating in sectors where they have a relative productive advantage compared to their competitors. Simultaneously, companies should ask themselves where they can deliver the best value to their customers. Conducting a value chain analysis prompts a firm to consider how each step adds or subtracts value from its final product or service. This, in turn, can help it realize some form of competitive advantage, such as:

- **Cost reduction**, by making each activity in the value chain more efficient and, therefore, less expensive
- **Product differentiation**, by investing more time and resources into activities like research and development, design, or marketing that can help the product stand out

Typically, increasing the performance of one of the four secondary activities can benefit at least one of the primary activities.

There are as such **five steps** in developing the value chain analysis

Step 1: Identify all value chain activities

Step 2: Calculate the cost of each activity

Step 3: Look at what your customers perceive as value

Step 4: Look at your competitors' value chains

Step 5: Decide on a competitive advantage

Q3

Postal Test Paper

What are the generic links of Porter’s Value Chain?

[8]

Reference	What's New
Primary and Support Activities	

Answer

Elements in Porter’s Value Chain

Rather than looking at departments or accounting cost types, Porter’s Value Chain focuses on systems, and how inputs are changed into the outputs purchased by consumers. Using this viewpoint, Porter described a chain of activities common to all businesses, and he divided them into primary and support activities, as shown below.

Primary Activities: Primary activities relate directly to the physical creation, sale, maintenance and support of a product or service. They consist of the following:

- **Inbound Logistics:** These are all the processes related to receiving, storing, and distributing the inputs internally. The supplier relationships are a key factor in creating value here.
- **Operations:** These are the transformation activities that change inputs into outputs that are sold to customers. Here, operational systems create value.
- **Outbound Logistics:** These activities deliver the product or service to the customer. These are the things like collection, storage, and distributing the outputs. They may be internal or external to the organisation.
- **Marketing and Sales:** These are the processes that are used to persuade clients to purchase from the firm instead of its competitors. The benefits being offered, and how well they are communicated to the customers, are sources of value here.
- **Service:** These are the activities related to maintaining the value of the product or service to customers, once it has been purchased.

Support Activities:

Support activities support the primary functions stated above. Each support, or secondary, activity can play a role in each primary activity. For example, procurement supports operations with certain activities, but it also supports marketing and sales with other activities.

- **Procurement (Purchasing):** This is what the organisation does to get the resources it needs to operate. This includes finding vendors and negotiating best prices.
- **Human Resource Management:** This is how well a company recruits, hires, trains, motivates, rewards, and retains its workers. People are a significant source of value, so businesses can create a clear advantage with good HR practices.

- **Technological Development:** These activities relate to managing and processing information, as well as protecting a company's knowledge base. Minimizing information technology costs, staying current with technological advances, and maintaining technical excellence are sources of value creation.
- **Infrastructure:** These are a company's support systems, and the functions that allow it to maintain daily operations. Accounting, legal, administrative, and general management are examples of necessary infrastructure that businesses can use to their advantage.

Q4

Dec '23

"Value Analysis is a methodical approach to sharpening the efficiency and effectiveness of any process" — In this context, summarise the phases of Value Analysis. (Any five) [7]

Reference	What's New
Phases of Value Analysis	

Answer

The Phases of Value Analysis are summarized as follows:

- (1) **Origination:** The phase of origination starts with the identification of a project to undertake value analysis. After selecting the project, a project team consisting of experts from various fields and departments is constituted.
- (2) **Information:** The second phase is that of collecting relevant information. In this phase, the relevant facts relating to specifications, drawings, methods, materials, etc. are collected. Costs are, also, ascertained for each of the elements that are being studied.
- (3) **Functional Analysis:** Then follows the important phase of functional analysis. After familiarisation with the relevant facts & figures, a functional analysis is carried out to determine the functions and uses of the product and its components. The cost and importance of each function are identified. A value index is computed on the basis of cost benefit ratio for each of the functions),
- (4) **Innovation:** This is the creative phase concerned with the generation of new alternatives to replace or remove the existing ones. The objective is to produce ideas and to formulate alternative means and methods for accomplishing the essential functions and improving the value of the element under consideration.
- (5) **Evaluation:** During the stage of evaluation, each and every alternative is analysed and the most promising alternatives are selected. These alternatives are further examined for economic and technical feasibility. The alternatives finally selected must be capable of performing the desired functions satisfactorily.

- (6) **Choice:** In this phase, the decision makers choose the best of alternatives. The programs and action plans are then developed to implement the chosen alternative.
- (7) **Implementation:** The chosen alternative is put to the actual use with the help of the programs and action plans. The progress of implementation is continuously monitored and followed up to ensure that the desired results are achieved.

SJC Institute

Value Chain Analysis and Value Engineering - Business Process Reengineering

Q1

June'23

"Business Process Re-engineering involves the radical redesign of core business processes to achieve dramatic improvements in productivity, cycle times and quality." In this context, **state** what are the **characteristics and principles** of Business Process Re-engineering. [6]

Reference	What's New
BPR	

Answer**Characteristics**

- (i) Several jobs are combined into one
- (ii) Very often workers make decisions
- (iii) The steps in the process are performed in a logical order
- (iv) Work is performed, where it makes most sense
- (v) Quality is built in
- (vi) Manager provides a single point of contact
- (vii) Centralized and decentralized operations are combined.

Seven Principles

- (i) Processes should be designed to achieve a desired outcome rather than focusing on existing tasks
- (ii) Personnel who use the output from a process should perform the process
- (iii) Information processing should be included in the work, which produces the information
- (iv) Geographically dispersed resources should be treated, as if they are centralized
- (v) Parallel activities should be linked rather than integrated
- (vi) Doers should be allowed to be self-managing
- (vii) Information should be captured once at source

Cost Control and Cost Reduction – Contemporary Techniques

Q1

Postal Test Paper

Differentiate Cost Control with Cost Reduction.

[4]

Reference	What's New
Cost Control and Cost Reduction	

Answer

Sl.	Nomenclature	Cost Control	Cost Reduction
1	Objective	Containing the cost in accordance with the pre-set targets	Exploring ways and means of improving the targets
2	Approach	Attaining lowest possible costs under the existing circumstances	A continuous process of analysis to find out new ways & means to achieve reduction in costs.
3	Nature	Preventive function	Corrective function
4	Emphasis	The emphasis is on the past i.e., on predetermined standards	The emphasis is on the present and the future i.e., on feasible permanent reductions
5	Assumptions	Assumes the existence of certain standards or norms	Assumes the existence of concealed potential savings in the standards or norms

Become Our **ROCKET STUDENT**

Register for **full group** of any level of **CA-CMA-CS** & get the following **BENEFITS**:

01

1 to 1 Preparation Assessment worth **Rs. 2499/-**

02

10% OFF on Next Group Combo

03

10% OFF on Group Mock Test Sangram (MTS)

04

10% OFF on One Stop Passing System (OSPS)

05

5% MONEY BACK for every Referral you give us

- You may choose from **any faculties** on SJC Website
- If you have registered only one subject, then you may register other subjects of the same group **within 15 days** to claim these benefits

Please connect with us at **8100 11 2222** with your registration details to know more



Quality Cost Management

2.1 Total Quality Management

2.2 Lean Accounting

2.3 Cost of Quality

SJC Institute

Total Quality Management

Q1

June'23; Postal Test Paper

Narrate the steps for implementing the Total Quality Management!

[8]

Reference	What's New
Steps for TQM	

Answer

STEPS IN TOTAL QUALITY MANAGEMENT

Step 1: Identification of customers/customer groups:

Through a team approach (a technique called **Multi-Voting**), the Firm should identify major customer groups. This helps in generating priorities in the identification of customers and critical issues in the provision of decision-support information.

Step 2: Identifying customer expectations:

Once the major customer groups are identified, their expectations are listed. The question to be answered is - **What does the customer expect from the Firm?**

Step 3: Identifying customer decision-making requirements and product utilities:

By identifying the need to stay close to the customers and follow their suggestions, a decision-support system can be developed, incorporating both financial and non-financial and non-financial information, which seeks to satisfy user requirements. Hence, the Firm finds out the answer to - **What are the customer's decision-making requirements and product utilities?** The answer is sought by listing out managerial perceptions and not by actual interaction with the customers.

Step 4: Identifying perceived problems in decision-making process and product utilities:

Using participative processes such as brainstorming and multi-voting, the Firm seeks to list out its perception of problem areas and shortcomings in meeting customer requirements. This will list out areas of weakness where the greatest impact could be achieved through the implementation of improvements. The Firm identifies the answer to the question - **What problem areas do we perceive in the decision-making process?**

Step 5: Comparison with other Firms and benchmarking:

Detailed and systematic internal deliberations allow the Firm to develop a clear idea of their own strengths and weaknesses and of the areas of most significant deficiency. Benchmarking exercise allows the Firm to see how other Companies are coping with similar problems and opportunities.

Step 6: Customer Feedback:

Steps 1 to 5 provide a information base developed without reference to the customer. This is rectified at Steps 6 with a survey of representative customers, which embraces their views on perceived problem areas. Interaction with the customers and obtaining their views helps the Firm in correcting its own perceptions and refining its processes.

Steps 7 & 8: Identification of improvement opportunities and implementation of Quality Improvement Process:

The outcomes of the customer survey, benchmarking and internal analysis, provides the inputs for Steps 7 and 8, i.e. the identification of improvement opportunities and the implementation of a formal improvement process. This is done through a six-step process called PRAISE, for short.

Q2

Postal Test Paper

What do you understand by 6C's?

[4]

<p>Reference 6C's</p>	<p>What's New</p>
---	--------------------------

Answer

The essential requirements for successful implementation are described as the **six C's of TQM**.

These are:

The 6C's

Commitment	If a TQM culture is to be developed, total commitment must come from top management. It is not sufficient to delegate 'quality' issues to a single person. Quality expectations must be made clear by the top management, together with the support and training required for its achievement.
Culture	Training lies at the centre of effecting a change in culture and attitudes. Negative perceptions must be changed to encourage individual contributions and to make 'quality' a normal part of everyone's job.

Continuous improvement	TQM should be recognised as a ' continuous process '. It is not a 'one-time programme'. There will always be room for improvement, however small it may be.
Co-operation	TQM visualises Total Employee Involvement (TEI). Employee involvement and co-operation should be sought in the development of improvement strategies and associated performance measures.
Customer focus	The needs of external customers (in receipt of the final product or service) and also the internal customers (colleagues who receive and supply goods, services or information), should be the prime focus.
Control	Documentation, procedures and awareness of current best practice are essential if TQM implementations are to function appropriately. Unless control procedures are in place, improvements cannot be monitored and measured nor deficiencies corrected.

Q3

June'23

SUNRISE PRAKASHAN LTD. is in the business of publishing a leading news paper which has a wide customer base. It measures quality of service in terms of:

- (i) Print quality
- (ii) On time delivery
- (iii) No. of damaged and unsold paper

To improve its business prospects and performance, the company is considering installing a scheduling and tracking system which involve an annual additional cost of ₹ 3,00,000 besides equipments costing ₹4,00,000 needed for the installation of system.

To purchase the equipment, the company is planning to utilize the proceeds of a investment fetching an income @9%. Details regarding the present and future performance are given as under :

	Present	Expected
On time delivery	80%	95%
Variable cost per lot of newspaper damaged and unsold (₹)	40	40
Fixed Cost (₹)	60,000	60,000
No. of lots of newspaper damaged and unsold	6,000	1,000

It is expected that each percentage increases in on time performance will result in revenue increase of ₹ 35,000 per annum. Required contribution margin is 40%.

Required :

Draw inference from the information given above and evaluate, whether Sunrise Prakashan Ltd. should install the new system. [5]

<p>Reference</p> <p>Evaluation of New System Installation</p>	<p>What's New</p>
---	--------------------------

Answer

TQM

Savings $(6,000 - 1,000) \times 40$	= 2,00,000
Inc contribution $(35,000 \times 15) \times 40\%$	= 2,00,000
	4,10,000
(-) Annual Cost	= 3,00,000
Eq Cost Int	= 36,000
	= 74,000

Q4

June'23 MTP Set 1

“A traditional approach to quality management is that there is an optimal level of quality effort, that minimizes total quality costs, and there is a point beyond which spending more on quality yields a benefit that is less than the additional cost incurred”.

Describe the principles of Total Quality Management (TQM) in the above context?
Distinguish those from the traditional approach to quality management? [3]

<p>Reference</p> <p>Principles of TQM</p>	<p>What's New</p>
---	--------------------------

Answer

In order to identify how and to what extent TQM differs from the traditional model of quality management, the philosophy behind the TQM is to be identified, which are;

- a) **Failure and poor quality are unacceptable.** It is inappropriate to think of an optimal level of quality at which some failures will occur, and the inevitability of errors is not something that an organisation should accept. The **target should be zero defects.**

- b) **Quality costs are difficult to measure**, and failure costs in particular are often seriously underestimated. The real costs of failure include not just the cost of scrapped items and reworking faulty items, but also the management time spent sorting out problems and the loss of confidence between different parts of the organisation whenever faults occur.
- c) A TQM approach does not accept that the prevention costs of achieving zero defects becomes unacceptably high as the quality standard improves and goes above a certain level. In other words, **diminishing returns do not necessarily set in**. If everyone in the organisation is involved in improving quality, the cost of continuous improvement need not be high.
- d) If an organisation **accepts an optimal quality level** that it believes will minimize total quality costs, there will be no further challenge to management to improve quality further.

Q5

June'23 MTP Set 2

Explain the principles of Total Quality Management (TQM). Also describe the essential requirements for the implementation of Total Quality Management (TQM)? [6]

 <p>Reference Principles and Essential Requirement of TQM</p>	<p>What's New</p>
--	--------------------------

Answer

TQM is a vision based, customer focused, prevention oriented, continuous improvement strategy based on scientific approach adopted by cost conscious people committed to satisfy the customers first time every time. It aims at Managing an organization so that it excels in areas important to the customer.

Principles of TQM are

- **Customer Focus:** The first of the Total Quality Management principles puts the focus back on the people buying your product or service. **Your customers determine the quality of your product.** If your product fulfills a need and lasts as long or longer than expected, customers know that they have spent their money on a quality product. When you understand what your customer wants or needs, you have a better chance of figuring out how to get the right materials, people, and processes in place to meet and exceed their expectations.
- **Total Employee Commitment:** You can't increase productivity, processes, or sales without the total commitment of all employees. They need to **understand the vision and goals** that have been communicated. They must be **sufficiently trained** and **given the proper resources** to complete tasks in order to be committed to reaching goals on time.

- **Process Approach:** Adhering to processes is critical in quality management. Processes ensure that the proper steps are taken at the right time to ensure **consistency and speed** up production.
- **Integrated System:** Typically, a business has many different departments, each with their own specific functions and purposes. These departments and functions should be **interconnected with horizontal processes** that should be the focus of Total Quality Management. But sometimes these departments and functions operate in isolated silos. In an integrated system, everybody in every department should have a thorough understanding of policies, standards, objectives, and processes. Integrated systems help the company to look for **continual improvement in order to achieve an edge over the competition.**
- **Strategic and Systematic Approach:** The International Organization for Standardization (ISO) describes this principle as: "Identifying, understanding and managing interrelated processes as a system contributes to the organization's effectiveness and efficiency in achieving its objectives." Multiple processes within a development or production cycle are managed as a **system of processes in an effort to increase efficiency.**
- **Continual Improvement:** Optimal efficiency and complete customer satisfaction do not happen in a day– your business should **continually find ways to improve processes** and adapt your products and services as customer needs shift.
- **Fact-based Decision-making:** Analysis and data gathering lead to better decisions based on the available information. **Making informed decisions leads to a better** understanding of customers and your market.
- **Communications:** Everybody in your organization needs to be aware of plans, strategies and methods that will be used to achieve goals. There is a greater risk of failure if you don't have a good communication plan.

The **essential requirements** for successful implementation are described as the six C's of TQM as tabulated below

- **Commitment** - If a TQM culture is to be developed, **total commitment must come from top management.** It is not sufficient to delegate 'quality' issues to a single person. Quality expectations must be made clear by the top management, together with the support and training required for its achievement.
- **Culture** - Training lies at the **centre of effecting a change in culture and attitudes.** Negative perceptions must be changed to encourage individual contributions and to make 'quality' a normal part of everyone's job.
- **Continuous Improvement** - TQM should be recognised as a 'continuous process'. It is not a 'one-time programme'. There will always be room for improvement, however small it may be.
- **Co-operation** - TQM visualises **Total Employee Involvement (TEI).** Employee involvement and cooperation should be sought in the development of improvement strategies and associated performance measures.

- **Customer Focus** - The needs of external customers (in receipt of the final product or service) and also the internal customers (colleagues who receive and supply goods, services or information), **should be the prime focus**.
- **Control** Documentation, procedures and awareness of current best practice are essential if TQM implementations are to function appropriately. **Unless control procedures are in place**, improvements cannot be monitored and measured nor deficiencies corrected.

SJC Institute

Chapter 2.2

Lean Accounting

Q1

June'23 MTP Set 1

Explain the notion of continuous improvement. **What** is the cornerstone of continuous improvement? [3]

<p>Reference</p> <p>Continuous Improvement - Notion & Cornerstone</p>	<p>What's New</p>
---	--------------------------

Answer

According to **Colin Drury** Continuous Improvement (CI) is an 'ongoing process that involves a continuous search to reduce costs, eliminate waste, and improve the quality and performance of activities that increase customer value or satisfaction'.

The implementation of continuous improvement **does not necessarily call for significant investment**, but it does require a great deal of **commitment and continuous effort**. Continuous improvement is often associated with incremental changes in the day-to-day process of work suggested by employees themselves. This is not to say that continuous improvement organisations do not engage in radical change. **Quantum leaps in performance can occur when cumulative improvements synergize**, the sum of a number of small improvements causing a profound net effect greater than the sum of all the small improvements. The process must be ongoing, and **sustained success is more likely in organisations** that regularly review their business methods and processes **in the drive for improvement**.

Cornerstones of continuous improvement (CI)

- **Quality** – the creation of key performance indicators (KPIs) with a focus on meeting customer needs was an important step in improving these processes. Previous measures had focused on output.
- **Process Improvements** – a process of benchmarking its KPIs means that Tata is always reviewing its activities, and by sharing relevant information within Tata, it maintains the drive necessary to keep the system working.
- **Teamwork** – CI requires everyone to work differently. Every employee needs to feel that they can and should spot areas of weakness and make suggestions about how to make

improvements. To help employees make this shift in attitude, a phased approach was used whereby initially CI coaches were responsible for CI, then CI champions, managers, team leaders and finally the team.

Q2

June'23 MTP Set 2

'Lean evolved from the manufacturing philosophy of the Toyota Production System' – **explain** the evolution process. In this context **explain** Lean Accounting and its three principles. [6]

Reference	What's New
Evolution, Meaning and Principles of Lean Accounting	

Answer

Taiichi Ohno (1912-1990) is more a symbol of Japan's manufacturing resurgence after the Second World War. Born in Dalian, in eastern China, he joined Toyota Automatic Loom Works between the wars. Ohno felt that there was no reason other than **inefficiency and wastefulness** why Toyota's productivity should be any lower than that of Detroit. Hence, he set out to eradicate inefficiency and eliminate waste in that part of the production process that he was responsible for. This became the core of the so-called **Toyota Production System (TPS)** that he and others subsequently developed between the mid-1940s and the mid-1970s. Several elements of this system have become familiar in the West; for example, **muda** (the elimination of waste), **jidoka** (the injection of quality) and **kanban** (the tags used as part of a system of just-in-time stock control). Lean was evolved from the manufacturing philosophy of the Toyota Production System.

The **cornerstone of lean is the elimination of waste from processes with a mindset of continuous improvement**. In its most basic form, Lean Manufacturing is the systematic elimination of waste by focusing on production costs, product quality and delivery, and worker involvement. It is said that the famed Toyota Production system was inspired by what the Toyota executives learned during their **visits to the Ford Motor Company** in the 1920s and developed by Toyota leaders such as Taiichi Ohno and consultant Shigeo Shingo after World War II. Broadly speaking, **Lean Manufacturing represents a fundamental paradigm shift from traditional "batch and queue" mass production to production systems based on product aligned "single-piece flow, pull production."** Whereas "batch and queue" involves mass-production of large inventories of products in advance based on potential or predicted customer demands, a "single-piece flow" system rearranges production activities in a way that processing steps of different types are conducted immediately adjacent to each other in a continuous and single piece flow. **If implemented properly, a shift in demand can be accommodated immediately, without the loss of inventory stockpiles associated with traditional batch-and-queue manufacturing.**

Lean Accounting is the application of lean thinking to all accounting and finance processes and systems. It is an essential component of a successful lean transformation for any organization. Lean accounting uses a method that **categorizes costs by value stream rather than by department**. This approach **“provides the basis for sound management decisions”**. The researchers define value stream accounting as **“tracking revenue and the associated variable costs required to generate those sales.”** It is experienced that value stream costing includes a simpler cost collection method and reduces the number of cost centers. They also list **features of value stream accounting as:**

- **Costs calculated weekly**
- **No distinction made between direct or indirect costs** – all costs of the value stream are considered direct costs
- **Value stream costs include** labour, materials, production support, machines and equipment, operation support, facilities and maintenance
- **Value stream costing provides** a more accurate picture by elimination of unnecessary costs outside control of value stream managers

Lean accounting groups together costs that fall outside of the value stream as “business sustaining costs” that do not get included in value stream costs. This, in turn, helps the businesses to find better price points for products and do further research into high-cost areas. The bottom line is that Lean accounting can help business leaders quickly know if they are heading in the right direction or need to make a change. **Three principles guide Lean Accounting and form the foundation for all of accounting’s work and interaction with the organization:**

- i. **Customer value:** Delivering the relevant and reliable information in a timely manner to all users of the information inside the organization.
- ii. **Continuous improvement:** Improving accounting processes, cross-functional business processes and the information used inside the business for analysis and decision making.
- iii. **Respect for people:** Adopting a learning attitude by seeking to understand root causes of business problems and issues in a cross-functional, collaborative manner.

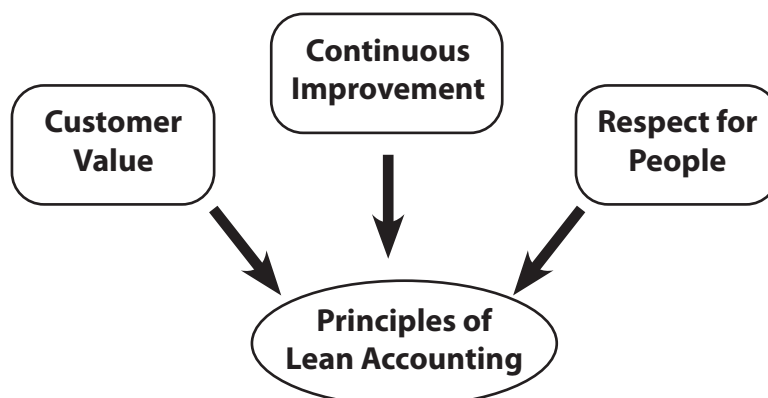

Q3
MTP Dec'23 Set 1

Narrate the principles, practices, and tools of lean accounting.

Reference Principles, Practices and Tools	What's New
--	-------------------

Answer

Sl.	Principles	Practices	Tools of lean accounting
1	Lean & simple business accounting	Continuously eliminates waste from the transactions, processes, reports, and other accounting methods	<ul style="list-style-type: none"> Value stream mapping; current & future state Kaizen (lean continuous improvement). PDCA (Planning, Doing, Checking and Acting) problem solving
2	Accounting processes that support lean transformation	Management control & continuous improvement	<ul style="list-style-type: none"> Performance Measurement Linkage Chart; linking metrics for cell/process, value streams, plant & corporate reporting to the business strategy, target costs, and lean improvement Value stream performance boards containing break-through and continuous improvement projects Box scores showing value stream performance
		Cost management	<ul style="list-style-type: none"> Value stream costing Value stream income statements
		Customer & supplier value and cost management	<ul style="list-style-type: none"> Target costing

3	Clear & timely communication of information	Financial reporting	<ul style="list-style-type: none"> • “Plain English” financial statements Simple, largely cash-based accounting
		Visual reporting of financial & non- financial performance measurements	Primary reporting using visual performance boards; division, plant, value stream, cell/ process in production, product design, sales/marketing, administration, etc.
		Decision-making	Incremental cost & profitability analysis using value stream costing and box scores
4	Planning from a lean perspective	Planning & budgeting	<ul style="list-style-type: none"> • Hoshin policy deployment. (Hosin Kanri (also called Policy Deployment is a method for ensuring that a company’s strategic goals drive progress and action at every level within that company. This method eliminates the waste that comes from inconsistent direction and poor communication). Sales, operations, & financial planning (SOFP)
		Impact of lean improvement	<ul style="list-style-type: none"> • Value stream cost and capacity analysis
		Capital planning	<ul style="list-style-type: none"> • Current state & future state value stream maps • Box scores showing operational, financial, and capacity changes from lean improvement. • Plan for financial benefit from the lean changes
		Invest in people	<ul style="list-style-type: none"> • Incremental impact of capital expenditure on value stream box-score. Often used with 3P approaches. (Production Preparation Process) • Performance measurements tracking continuous improvement participation, employee satisfaction & cross- training Profit sharing

5	Strengthen internal accounting control	Internal control based on lean operational controls	<ul style="list-style-type: none"> • Transaction elimination matrix • Process maps showing controls and SOX risks. (A SOX control is a rule that prevents and detects error within a process cycle of financial reporting. These controls fall under the Sarbanes-Oxley Act of 2002 (SOX). SOX is a U.S. federal law requiring all public companies doing business in the United States to comply with the regulation).
		Inventory valuation	<ul style="list-style-type: none"> • Simple methods to value inventory without the requirement for perpetual inventory records and product costs can be used when the inventory is low and under visual control.

SJC Institute

Chapter 2.3 Cost of Quality

Q1

June'23 MTP Set 2

Rags Ltd. manufactures and sells premium quality of sports shoes in India. Noted sports clubs and its members are the main customers. Finished products show some rectifiable defects. These problems can be detected and rectified during internal inspection. Inspection cost is ₹30 per unit. Rectification cost is ₹18 per unit. During 2022, 60000 pairs of shoes were manufactured and sold. After inspection defect was detected in respect of 5% of output. Inspection cost is ₹ 30 per pair. After sales, customers reported defects in respect of 6% of output. These shoes were received back from customers at a transportation cost of ₹ 10 per pair. Due to negative publicity arising out of sale of defective materials, loss in sales is expected in next year to the extent of 5% of external failures.

Required:

- a. **Calculate** the cost of quality showing the elements separately.
- b. If the selling price per pair of shoes is ₹ 600 and variable cost is 60% of sales, fixed cost is ₹5,50,000 p.a., **prepare** the profitability statement for the product during 2022. [2 + 3 = 5]



Reference

Cost of Quality & Profitability

What's **New**

Answer

(a) Statement of Costs of Quality

	₹
(a) Inspection or Appraisal Cost (30 x 60,000 shoes)	18,00,000
(b) Internal failure (re-work) cost (5% x 60,000 x ₹ 18)	54,000
(c) External failure cost (i.e., transportation + re-work cost) [6% x 60,000 x (₹ 10 + 18)]	1,00,800
(d) Opportunity cost (i.e., loss of contribution) [5% x (6% x 60,000) x (₹ 600 x 40%)]	43,200
Total Quality Cost	19,98,000

(b) Profitability Statement

	₹
Sales (60,000 x ₹ 600)	3,60,00,000
Less: Variable Cost (60%)	2,16,00,000
Contribution	1,44,00,000
Less: Quality Cost (as above)	19,98,000
Contribution, net of quality costs	1,24,02,000
Less: Fixed Cost	5,50,000
Net Profit	1,18,52,000

Q2**June'23**

The following financial information has been extracted from the records of ASHREEN LTD. for analyzing the cost of quality for the year 2022-2023:

- (i) Sales Revenue for the year: ₹ 400 lakh
- (ii) During the year, customers returned 40,000 units needing repair, repair cost averages ₹ 8 per unit.
- (iii) Six Inspectors are employed each earning an annual salary of ₹ 2,00,000. These six inspectors are involved only with final inspection (Product acceptance).
- (iv) Total Scrap is 30,000 units. All scraps are quality related. The cost of scrap is about ₹ 20 per unit.
- (v) During the year, approximate 1,20,000 units are rejected in final inspection. Of these units, 90 per cent can be recovered through rework. The cost of rework is ₹ 8 per unit.
- (vi) The company employs 5 full time employees in the complaint department. Each earns ₹1,00,000 for this year.
- (vii) The company requires all new employees to take three hour quality training programme. The estimated cost for the programme is ₹ 1,50,000.
- (viii) Inspection of the final products require testing equipment. The annual cost of operating and maintaining this equipment is ₹ 1,80,000

Required:

- (I) **Analyse** the costs of quality showing its elements separately with workings.
- (II) If the selling price per unit is ₹ 50 and variable cost is 60% of the sales and fixed costs ₹ 70 lakh per annum. **Determine** what will be the profit (Net of quality costs) of the company for the year 2022-2023. [4 + 3 = 7]



Reference

Cost of Quality Analysis, Profit of the CompanyWhat's **New****Answer**

- (i) Cost of Quality = ₹ 38,14,000
- (ii) Net Profit = ₹ 51,86,000

SJC Institute

One-Stop Pass System

For students who needs a push to study with continuous evaluation system but have taken classes haphazardly

SCAN HERE



Sure Shot Batch

आप बस पढाई कीजिए
पूरी PLANNING हमारी

SCAN HERE



BOUNCE BACK ASSESSMENT

To Bounce Back you need to do something different. But what? Take our Bounceback Assessment to know.

SCAN HERE



PREPARATION ASSESSMENT

Know whether you are
on the right track

SCAN HERE



Mock test Sangram

The more you sweat in practice, the less you bleed in Battle

SCAN HERE



Rankers Batch

Are you aiming for a
top rank in exams?
Join our Rankers Batch

SCAN HERE



Decision Making Techniques

3.1 Decisions Involving Alternative Choices

3.2 Relevant Cost Analysis

3.3 Asset Life Cycle Costing

3.4 Transfer Pricing

3.5 Decision Making using Probability

Decisions Involving Alternative Choices

Q1

June'23

You have been approached by a friend who is seeking your advice as to whether he should give up his job as an engineer, with a current salary of ₹ 14,800 per month and go into business on his own, assembling and selling a component which he has invented. He can procure the parts required to manufacture the component from a supplier.

It is very difficult to forecast the sales potential of the component, but after some research, your friend has estimated the sales as follows:

- (i) Between 600 to 900 components per month at a selling price of ₹ 250 per component.
- (ii) Between 901 to 1,250 components per month at a selling price of ₹ 220 per component for the entire lot.

The costs of the parts required would be 140 for each completed component. However, if more than 1,000 components are produced in each month, a discount of 5% would be received from the supplier of parts on all purchases.

Assembly costs would be ₹ 60,000 per month upto 750 components. Beyond this level of activity assembly costs would increase to ₹ 70,000 per month.

Your friend has already spent ₹ 30,000 on development, which he would write off over the first five years of the venture.

Required:

- (i) **Analyse** the information stated supra and formulate by way of calculating for each of the possible sales levels at which your friend could expect to benefit by going into the venture on his own.
- (ii) **Formulate** by way of calculating the breakeven point of the venture for each of the selling price and suggest your friend on each level of break-even point.
- (iii) **Advise** your friend as to the viability of the venture.



Reference

Evaluation of New Business

What's New

Break Even Point

Answer

- I. The salary of ₹ 14,800 per month is a benefit foregone by going into business. It should therefore be considered as a minimum profit which must be earned p.m. from the new venture in order to be not worse-off than before.
- II. Sum of ₹ 30,000 spent on the development work of the new venture cannot be recovered irrespective of the decision and thus it should be ignored.
- III. Advise on the viability of the venture:
 - (a) At a selling price of ₹ 250 he will not be at a loss if the demand of the component exceeds 680 units to 749 units and 770.909 units to 900 units.
 - (b) At a selling price of ₹ 220, it is not worthwhile to sell if the demand is less than 1000 components without availing a discount of 5%.

Q2

June'23 MTP Set 1

A Company manufacturing a highly successful line of cosmetics intends to diversify the product line to achieve fuller utilization of its plant capacity. As a result of considerable research made the company has been able to develop a new product called 'EMO'. EMO is packed in tubes of 50 grams capacity and is sold to the wholesalers in cartons of 24 tubes at ₹ 240 per carton. Since the company uses its spare capacity for the manufacture of EMO, no additional fixed expenses will be incurred. However, the cost accountant has allocated a share of ₹ 4,50,000 per month as fixed expenses to be absorbed by EMO as a fair share of the company's present fixed costs to the new production for costing purposes. The company estimated the production and sale of EMO at 3,00,000 tubes per month and on this basis the following cost estimates have been developed.

	₹ per carton
Direct Materials	108
Direct Wages	72
All overheads	54
Total costs	234

After a detailed market survey, the company is confident that the production and sales of EMO can be increased to 3,50,000 tubes and the cost of empty tubes, purchased from outside will result in a saving of 20% in material and 10% in direct wages and variable overhead costs of EMO. The price at which the outside firm is willing to supply the empty tubes is ₹1.35 per empty tube. If the company desires to manufacture empty tubes in excess of 3,00,000 tubes, new machine involving an additional fixed overheads ₹ 30,000 per month will have to be installed.

Required:

- (i) **Discuss** with reasons as the Cost Accountant of the company whether it should make or buy the empty tubes at each of the three volumes of production of EMO namely 3,00,000; 3,50,000 and 4,50,000 tubes.
- (ii) At **what** volume of sales will it be economical for the company to install the additional equipment for the manufacture of empty tubes?
- (iii) **Determine** the profitability on the sale of EMO at each, of the aforesaid three levels of output based on your decision and showing the cost of empty tubes as a separate element of cost. [3 + 2 + 3 = 8]

<p>Reference</p> <p>Evaluation of Make or Buy</p>	<p>What's New</p>
---	--------------------------

Answer

(i) **Make or Buy**

Total Cost per tube of EMO:

	Per Tube
Direct Material = (108 ÷ 24)	= ₹ 4.50
Direct Wages = (72 ÷ 24)	= ₹ 3.00
Variable Overheads = {(54 ÷ 24) – (4,50,000 ÷ 3,00,000)}	= ₹ 0.75

Particulars	Total Cost (₹)	Tube Cost (₹)	Product Cost (₹)
Material	4.50	20% of total cost = 0.90	3.60
Wages	3.00	10% of total cost = 0.30	2.70
Variable Overhead	0.75	10% of total cost = 0.075	0.675
Total	8.25	1.275	6.975

Cost of Making = (3,00,000 × 1.275) = ₹ 3,82,500

Cost of Buying = (3,00,000 × 1.35) = ₹ 4,05,000

Therefore, it is better to make the tubes at 3,00,000 level of output, as it is cheaper than Buying.

Computation of Cost for additional tubes at the level of 3,50,000 and 4,50,000:

Particulars	3,50,000	4,50,000
Additional tubes needed over 3,00,000	50,000	1,50,000

Cost of Making (₹)	93,750 [(50,000×1.275)+30,000]	2,21,750 [(1,50,000×1.275)+ 30,000]
Cost of Buying (₹)	67,500 (50,000 × 1.35)	2,02,500 (1,50,000 × 1.35)

From the above, it is better to Buy the empty tubes at the level of 3,50,000 and 4,50,000, as it is deeper than making at both levels.

(ii) **The level at which it is beneficial to make the tubes over and above 300000 units**

Additional Fixed Overheads = ₹ 30,000

Excess of buying cost over variable cost = (1.35 - 1.275) = ₹ 0.075

Indifference Point = (Additional Fixed Overheads ÷ Excess Buying Cost)

$$= 30,000 \div 0.075$$

$$= 4,00,000 \text{ units}$$

Therefore, the Company will be justified to install the additional Equipment for the manufacture of Empty tubes at a sales volume of 400000 units.

(iii) **Evaluation of Profitability at the three levels of output**

Sl. No.	Particulars	3,00,000	3,50,000	4,00,000
(i)	Sales @ ₹ 10 p.u.	30,00,000	35,00,000	45,00,000
(ii)	Product Cost @ ₹ 6.975 p.u.	20,92,500 (3,00,000×6.975)	24,41,250 (3,50,000×6.975)	31,38,750 (4,50,000×6.975)
(iii)	Tube Cost (₹) [As per (i)]	3,82,500 (3,00,000×1.275)	4,72,500 (3,50,000 × 1.35)	6,07,500 (4,50,000×1.35)
(iv)	Fixed cost (₹)	4,50,000	4,50,000	4,50,000
(v)	Total Cost (₹)	29,25,000	33,63,750	41,96,250
(vi)	Profit (I-V) (₹)	75,000	1,36,250	3,03,750

Q3

June'23 MTP Set 1

A company makes three products X, Y and Z. All three products use the same type of labour which is limited to 1,000 hours per month. Individual details are as follows;

Product	X	Y	Z
Contribution/unit	₹ 25	₹ 40	₹ 32
Labour hours/unit	5	6	8
Maximum demand	50	100	400

Suggest the management on the optimal product mix.

[4]

Reference	What's New
Key Factor - Optimal Product Mix	

Answer

Contribution per labour hour of X = ₹ 25 ÷ 5 = ₹ 5 (2nd)

Contribution per labour hour of Y = ₹ 40 ÷ 6 = ₹ 6.67 (1st)

Contribution per labour hour of Z = ₹ 32 ÷ 8 = ₹ 4 (3rd)

Quantities produced

	Hours
100 units of Y	600
50 units of X	250
18.75 unit of Z	150 (balance)
	1,000

Since it would not be practical to produce 0.75 of a unit, we would produce 18 units of product Z with 6 spare hours.

Q4

Postal Test Paper

The income statement of Ashok Gears Ltd. is summarized as below:

Net Revenue	₹ 80,00,000
Less: Expenses (including ₹40,00,000 of Fixed Cost)	₹ 88,00,000
Net Loss	₹ 8,00,000

The manager believes that an increase of ₹20,00,000 as fixed expenditure in advertising outlays will increase the sales substantially. His plan was approved by the Board.

You are required to **calculate**:

- (i) At **what** sales volume will the Company have break even?
- (ii) **What** sales volume will result in a Net Profit of ₹ 4,00,000? [4]

Reference	What's New
Sales Volume to Break Even & to Earn Profit	

Answer

(i) Computation of Break-Even Sales

Net Revenue	= ₹ 80,00,000	
Variable Expenses	= ₹ (88,00,000 - 40,00,000)	= ₹ 48,00,000
Contribution	= (80,00,000 - 48,00,000)	= ₹ 32,00,000
Contribution Margin Ratio	= 32,00,000 ÷ 80,00,000	= 40% (PV Ratio)
Revised Fixed Cost	= (Existing 40,00,000 + 20,00,000 of Advertising)	
	= ₹ 60,00,000	
Break Even Sales	= (Fixed Cost ÷ PV Ratio)	= (60,00,000 ÷ 40%)
		= ₹ 1,50,00,000

(ii) Computation of sales level to earn a Net Profit of ₹ 4,00,000

Targeted Contribution	= (Fixed Cost + Desired Profit)
	= (60,00,000 + 4,00,000) = ₹ 64,00,000
Required Sales	= (Targeted Contribution ÷ PV Ratio)
	= (64,00,000 ÷ 40%)
	= ₹ 1,60,00,000

(Explanatory Comment: The problem brings forth the primary application of marginal costing in manufacturing sector for the purposes of calculating the BEP and profit planning.)

Q5

MTP Dec'23 Set 1

Forward and Foundry Ltd. is feeling the effects of a general recession in the industry. Its budget for the coming half year is based on an output of only 500 tonnes of casting a month which is less than half of its capacity. The prices of casting vary with the composition of the metal and the shape of the mould, but they average ₹ 175 a tonnes. The following details are from the Monthly Production Cost Budget at 500 tonnes levels:

	Core making	Melting and Pouring	Moulding	Cleaning and Grinding
	₹	₹	₹	₹
Labour	10,000	16,000	6,000	4,500
Variable overhead	3,000	1,000	1,000	1,000
Fixed overhead	5,000	9,000	2,000	1,000
	18,000	26,000	9,000	6,500
Labour and O.H. rate per direct labour hour	9.00	6.50	6.00	5.2

Operation at this level has brought the company to the brink of break-even. It is feared that if the lack of work continues, the company may have to lay off some of the most highly skilled workers whom it would be difficult to get back when the volume picks up later on. No wonder, the work's Manager at this Juncture, welcomes an order for 90,000 casting, each weighing about 40 lbs., to be delivered on a regular schedule during the next six months. As the immediate concern of the Works Manager is to keep his work force occupied, he does not want to lose the order and is ready to recommended a quotation on a no-profit and no-loss basis.

Materials required would cost ₹ 1 per casting after deducting scrap credits. The direct labour hour per casting required for each department would be:

Core Making	0.09
Melting and pouring	0.15
Moulding	0.06
Cleaning and grinding	0.06

Variable overheads would bear a normal relationship to labour cost in the melting and pouring department and in the moulding department. In core making, cleaning and grinding however, the extra labour requirements would not be accompanied by proportionate increases in variable overhead. Variable overhead would increase by ₹1.20 for every additional labour hour in core making and by 30 paise for every additional labour hour in cleaning and grinding. Standard wage rates are in operation in each department and no labour variances are anticipated.

To handle an order as large as this, certain increases in factory overheads would be necessary amounting to ₹ 1,000 a month for all departments put together. Production for this order would be spread evenly over the six months period.

You are **required** to:

- (a) **Prepare** a revised monthly labour and overhead cost budget, reflecting the addition of this order.
- (b) **Determine** the lowest price at which quotation can be given for 90,000 castings without incurring a loss.

Reference

Lowest Price Computation

What's **New**

Revised Labour & Overhead Budget

Answer

Computation of Labour and Overhead Rate

	Core making	Melting & pouring	Moulding	Cleaning & grinding
Labour & overheads (₹)	18,000.00	26,000.00	9,000.00	6,500.00
Labour & overheads per hour (₹)	9.00	6.50	6.00	5.20
No. of hours	2,000.00	4,000.00	1,500.00	1,250.00
Variable overhead per hour (₹)	1.50	0.25	0.67	0.80
Labour rate per hour (₹)	5.00	4.00	4.00	3.60
Hours required for new order	1,350.00	2,250.00	900.00	900.00
Labour cost required for order (₹)	6,750.00	9,000.00	3,600.00	3,240.00
Variable overhead cost for order (₹)	1,620.00	563.00	600.00	270.00

Revised monthly labour and overheads cost budget reflecting the additions of the order

	Core Making ₹	Melting & Pouring ₹	Moulding ₹	Cleaning & Grinding ₹	Total ₹
Labour	10,000.00	16,000.00	6,000.00	4,500.00	
Labour for the order	6,750.00	9,000.00	3,600.00	3,240.00	
	16,750.00	25,000.00	9,600.00	7,740.00	
Variable overheads	3,000.00	1,000.00	1,000.00	1,000.00	
Variable overheads for the order	1,620.00	563.00	600.00	270.00	
	4,620.00	1,563.00	1,600.00	1,270.00	
Fixed cost	5,000.00	9,000.00	2,000.00	1,000.00	
Total	26,370.00	35,563.00	13,200.00	10,010.00	85,143.00

Add : additional fixed cost					1,000.00
				Total:	86,143.00

Computation of total price for the order

		₹
Material	(15,000 × 1)	15,000.00
Labour & overheads	(86,143 – 59,500)	26,643.00
		41,643.00
Total price for the order	(41,643 × 6)	2,49,858

SJC Institute

Chapter 3.2

Relevant Cost Analysis

Q1

June'23 MTP Set 1

Mr Belle has recently developed a new improved video cassette and shown below is a summary of a report by a firm of management consultants on the sales potential and production costs of the new cassette. Sales potential: The sales volume is difficult to predict and will vary with the price, but it is reasonable to assume that at a selling price of ₹ 10 per cassette, sales would be between 7,500 and 10,000 units per month. Alternatively, if the selling price was reduced to ₹ 9 per cassette, sales would be between 12,000 and 18,000 units per month. Production costs: If production is maintained at or below 10,000 units per month, then variable manufacturing costs would be approximately ₹ 8.25 per cassette and fixed costs ₹ 12,125 per month. However, if production is planned to exceed 10,000 units per month, then variable costs would be reduced to ₹ 7.75 per cassette, but the fixed costs would increase to ₹ 16,125 per month. Mr. Belle has been charged ₹ 2,000 for the report by the management consultants and, in addition, he has incurred ₹ 3,000 development costs on the new cassette. If Mr. Belle decides to produce and sell the new cassette it will be necessary for him to use factory premises which he owns, but are leased to a colleague for a rental of ₹400 per month. Also he will resign from his current post in an electronics firm where he is earning a salary of ₹ 1,000 per month.

Required:

- a) **Draw** inference from the information given above and identify the following
 - (i) an opportunity cost,
 - (ii) a sunk cost.
- b) Making whatever calculations you consider appropriate, **analyze** the report from the consultants and advise Mr. Belle of the potential profitability of the alternatives shown in the report.
- c) You are **required** to analyze the basis on which the above decisions are applied and state the assumptions considered necessary or matters which may require further investigation or comment should be clearly stated. [2 + 4 + 2 = 8]

Reference

Opportunity Cost, Sunk Cost - Evaluation based on BES & MOS

What's New

Answer

- (a) (i) The opportunity costs of producing cassettes are the salary forgone of ₹ 1,000 per month and the rental forgone of ₹ 400 per month.
- (ii) The consultant's fees and development costs represent sunk costs.
- (b) The following information can be obtained from the report.

	₹ 10 Selling price	₹ 9 selling price
Sales quantity	7500 – 10000 units	12000 – 18000 units
Fixed costs ^a	₹ 13,525	₹ 17,525
Profit at maximum sales ^b	₹ 3,975	₹ 4,975
Profit/(Loss) at minimum sales ^c	(₹ 400)	(₹ 2,525)
Break-even point ^d	7729 units	14020 units
Margin of safety:		
Below maximum	2271 units	3,980 units
Above minimum	229 units	2020 units

Notes:

- a Fixed production cost + ₹ 1,400 opportunity cost
- b (10000 units × ₹ 1.75 contribution) – ₹ 13,525 fixed costs = ₹ 3,975 profit
 (18000 units × ₹ 1.25 contribution) – ₹ 17,525 fixed costs = ₹ 4,975 profit
- c (7500 units × ₹ 1.75 contribution) – ₹ 13,525 fixed costs = ₹ 400 loss
 (12000 units × ₹ 1.25 contribution) – ₹ 17,525 fixed costs = ₹ 2,525 loss
- d Fixed costs / contribution per unit

Conclusions

- (i) The ₹ 10 selling price is less risky than the ₹ 9 selling price. With the ₹ 10 selling price, the maximum loss is lower and the break-even point is only 3% above minimum sales (compared with 17% for a ₹ 9 selling price).
- (ii) The ₹ 9 selling price will yield the higher profits if maximum sales quantity is achieved.
- (iii) In order to earn ₹ 3975 profits at a ₹ 9 selling price, we must sell 17,200 units (required contribution of 17,525 fixed costs plus ₹ 3,975 divided by a contribution per unit of ₹ 1.25).

(c) **Additional information required:**

These are the assumptions

- (i) Details of capital employed for each selling price.
- (ii) Details of additional finance required to finance the working capital and the relevant interest cost so as to determine the cost of financing the working capital.
- (iii) Estimated probability of units sold at different selling prices.

- (iv) How long will the project remain viable?
 (v) Details of range of possible costs. Are the cost figures given in the question certain?

Q2

June'23 MTP Set 2

ASA LLP has been approached by a customer who would like a special job to be done for him and is willing to pay ₹ 22,000 for it. The job would require materials A, B, C and D. the details of the material are given below;

Materials	Total units required	Units already in inventory	Book Value of units in stock (₹ per unit)	Realisable Value (₹ per unit)	Replacement Cost (₹ per unit)
A	1000	0	-	-	6
B	1000	600	2	2.5	5
C	1000	700	3	2.5	4
D	200	200	4	6	9

The following information are also furnished.

- (i) Material B is used regularly by X Ltd. and if stocks were required for this job, they would need to be replaced to meet other production demand.
- (ii) Materials C and D are in stock as the result of previous excess purchase and they have a restricted use. No other use could be found for material C but material D could be used in another job as substitute for 300 units of material which currently costs ₹ 5 per unit (of which the company has no units in stock at the moment.)
- (iii) Assume all other expenses on this contract to be specially incurred besides the relevant cost of material is ₹ 550.

Analyze the relevant costs of material, in deciding whether or not to accept the contract? [7]

Reference	What's New
Relevant Costs of Material	

Answer

Computation of relevant costs of Material

Material	Relevant Cost	Workings	Amount (₹)
A	Replacement Cost	(1000 × 6)	6,000.00
B	Replacement Cost	(1000 × 5)	5,000.00

C	Realisable Value for 700 units and Replacement Cost for 300 units	$[(700 \times 2.5) + 300 \times 4]$	2,950.00
D	Substitution Cost	(300×5)	1,500.00
	Sub Total		15,450.00
	Add: Other expenses		550.00
	Total		16,000.00

As the revenue from the order, is more than the relevant costs of ₹ 16,000 the order should be accepted.

Justification of the solution for each material is given as under

- **Material A:** Since it is not in stock, needs to be purchased from market at replacement cost, hence it is Relevant
- **Material B:** It is in stock and is being regularly used for other production demand. So it needs to be purchased from market at replacement cost, hence it is Relevant
- **Material C:** partly available Ex stock, so realisable value is relevant and balance needs to be purchased from market at replacement cost, hence it is Relevant
- **Material D:** available ex stock but it can be used for other job where replacement cost is 300 units @ ₹ 5 each so $300 \times 5 = 1500$ is relevant cost

Q3

June'23

SONTECH LTD., a machine manufacturing company, had nearly completed a job relating to construction of specialized equipment when it discovered that the customer had gone into liquidation. At this stage, the position of the job was as under:

	₹
Original cost estimated	1,75,200
Costs incurred so far	1,48,500
Costs to be incurred	29,700
Progress payments received from original customer	1,00,000

After searches, a new customer for the Equipment has been found. He is interested to take the equipment if certain modifications are carried out. The new customer wants the equipment in its original condition, but without its control device and with certain other modifications. The costs of these additions and modifications are estimated as under :

Direct materials at cost : ₹ 1,050

Direct Wages : ₹ 3,500

Variable overheads: 25% of direct Wages

Delivery costs: ₹ 1,350

Fixed overheads will be absorbed at 50% of direct wages.

The following additional information is available:

- (i) The direct materials required for the modification are in stock and if not used for modification of the order, they will be used in another job in place of materials that will now cost ₹ 2,250.
- (ii) The Department is extremely busy. Its direct wages is ₹ 2,500 and currently yielding a contribution of ₹ 3.20 per rupee of direct wages.
- (iii) Supervisory overtime payable for the modification is ₹ 1,050.
- (iv) The cost of control device that the new customer does not require is ₹ 13,500. If it is taken out, it can be used in another job in place of a different mechanism. This latter mechanism has otherwise to be bought for ₹ 10,500. The dismantling and removal of the control mechanism is ₹ 120.
- (v) If the conversion is not carried out, some of the materials in the original equipment can be used in another contract in place of materials that would have cost ₹ 12,000. It would have taken wages cost of ₹ 240 to make them suitable for this purpose. The remaining materials will realize ₹ 11,400 as scrap. The drawings, which are included as part of the job, can be sold for ₹ 1,500.

Required:

Analyse the relevant costs of equipment in deciding at what minimum price that the company can afford to quote for the new customer. [7]

Reference	What's New
<ul style="list-style-type: none"> ☞ Minimum Price based on Relevant Costing 	

Answer

The minimum price that SONTECH Ltd. can afford to quote for the new Customer is ₹ 60945.

Q4

Dec '23

RONTEX LTD., (Builders) has been offered a contract by Exyan Lid. to build for it five special Guest Houses for use by top management. Each guest house will be an independent one. The contract will be for a period of one year and the offer price is ₹ 1 crore. In addition Exyan Ltd. will also provide 2 grounds of land free of cost for the purpose of construction.

The Chief Accountant of Rontex T.td. has prepared an estimate on the basis of which he has that the contract should not be accepted at the price offered. His estimate was as follows:-

	₹ in Lakhs
Tintakn Land (3 Grounds at ₹ 20 lakh cach)	60
Drawing and Design	7
Registration	10
Materials:	
Cement and Sand	6
Bricks and Tiles	4
Steel	10
Others (Including interior d ccoration)	10
Labour-Skilled	12
-Unskilled	8
Supervisor's Salary	6
Overheads General	12
Depreciation	6
Total Cost	150

The Accountant also provides the following information;

Land: The total requirement of land is 3 grounds costing ₹ 20 lacs per ground, Exyan Ltd, will provide 2 grounds free of cost.

Drawing and Design: These have already been prepared and 50% of the cost has already been incurred.

Materials:

- (i) Cerent and Sand are already in stock and are in regular use, if used for this contract, they have to be replaced at a cost of ₹ 8 Lakh.
- (ii) Bricks and Tiles represent purchases made several months before for a different contract. They could be sold readily for a net ₹ 5 lakh after meeting all further expensed.
- (iii) Others: Materials worth ₹ 2 lakh relating o interior decoration are in stock for which no alternative use is expected in the near future. However, they can be sold for ₹ 1 lakh.

Labour:

- (i) Skilled workers will be transferred to this project from another project. The project manager claimed that if the men were returned to him, he could have earned the company an additional ₹ 2 lakh in terms of profits.
- (ii) The supervisor undertakes various tasks in the sites and his pay and continuity of employment will not be affected by the new contract. If the contract is taken, he will devote half of his time.

Overheads:

- (i) The equipment that would be used on the contract was bought one year before for ₹ 30 lakh and is expected to last for five years. It can also be used on other contracts and the current replacement price will be ₹ 232 lakh and in a year's time it will be ₹ 25 lakh.
- (ii) The general overheads includes both specific and absorbed overheads. If the contract is not undertaken, ₹ 4 lakh of the same can be avoided.

RONTEX LTD. has also on hand another project, which would not be executed if the contract from Exyan Ltd. were to be accepted. The estimated profit on that project is ₹ 10 lakh.

Required:

- (a) **Draw** inference from the information given supra and identify the following.
 - (i) Relevant cost if the contract is accepted
 - (ii) Irrelevant cost if the contract is accepted
- (b) **Indicate** with reasons as a cost and management accountant of the company whether it should accept the contract from Exyan Ltd. or not. [14]

Reference	What's New
Relevant and Irrelevant cost of Contract	

Answer

- (a) (i) Relevant cost if the contract is accepted ₹ 93 lakh.
- (ii) Irrelevant cost if the contract is accepted ₹ 18 lakh.
- (b) **Decision:**

Since the offer price of contract is ₹ 1 crore and its total relevant cost is ₹ 93 Lakh these figures clearly shows that the offer should be accepted.

Chapter 3.3

Asset Life Cycle Costing

Q1

June'23 MTP Set 1

Company X is forced to choose between two machines A and B. The two machines are designed differently but have identical capacity and do exactly the same job. Machine A costs ₹1,50,000 and will last for 3 years. It costs ₹40,000 per year to run. Machine B is an 'economy' model costing only ₹1,00,000, but will last only for 2 years, and costs ₹60,000 per year to run. These are real cash flows. The costs are forecasted in rupees of constant purchasing power. Ignore tax. Opportunity cost of capital is 10%.

Suggest the management as to which machine it should buy. [4]

<p>Reference</p> <p>Equivalent Annual Cost</p>	<p>What's New</p>
--	--------------------------

Answer

Compound present value of 3 years @ 10%	= 2.486	
P.V. of running cost of Machine A for 3 years	= ₹ 40,000 x 2.486	= ₹ 99,440
Compound present value of 2 years @ 10%	= 1.735	
P.V. of running cost of Machine B for 2 years	= ₹ 60,000 x 1.735	= ₹ 1,04,100

Statement Showing Evaluation of Machines A and B (₹)

Particulars	Machine A	Machine B
Cost of purchase	1,50,000	1,00,000
Add: P.V. of running cost for 3 years	99,440	1,04,100
P.V. of Cash outflow	2,49,440	2,04,100
	2,49,440	2,04,100
Equivalent present value of annual cash outflow	2.486	1.735
	= 1,00,338	= 1,17,637

Analysis: Since the annual cash outflow of Machine B is higher, Machine A can be purchased.

Chapter 3.4

Transfer Pricing

Q1

June'23 MTP Set 2

Kobe Co manufactures electronic mobility scooters. The company is split into two divisions: the scooter division (Division S) and the motor division (Division M). Division M supplies electronic motors to both Division S and to external customers. The two divisions run as autonomously as possible, subject to the group's current policy that Division M must make internal sales first before selling outside the group; and that Division S must always buy its motors from Division M. However, this company policy, together with the transfer price which Division M charges Division S, is currently under review.

Details of the two divisions are given below.

Division S

Division S's budget for the coming year shows that 35 000 electronic motors will be needed. An external supplier could supply these to Division S for ₹ 800 each.

Division M

Division M has the capacity to produce a total of 60 000 electronic motors per year. Details of Division M's budget, which has just been prepared for the forthcoming year, are as follows:

Budgeted sales volume (units)	60 000
Selling price per unit for external sales of motors	₹ 850
Variable costs per unit for external sales of motors	₹ 770

Maximum external demand for the motors is 30 000 units per year.

Required:

Assuming that the group's current policy could be changed, **determine**, using suitable calculations, the number of motors which Division M should supply to Division S in order to maximize group profits. **Calculate** the transfer price or prices at which these internal sales should take place. **Note:** All relevant workings must be shown

The variable cost per unit for motors sold to Division S is ₹ 30 per unit lower due to cost savings on distribution and packaging. [4]

Reference	What's New
No. of units to be transferred, Transfer Price	

Answer

Division M generates a contribution to profit of ₹ 80 (₹ 850 – ₹ 770) for the group as a whole for every motor sold externally. The incremental cost for every motor which Division S has to buy from outside of the group is ₹ 60 per unit (₹ 800 – [₹ 770 – ₹ 30]). Therefore, from the group's perspective as many external sales as possible should be made before any internal transfers are made. Division M's total capacity is 60000 units so 30000 units should be sold externally and the remaining 30000 units transferred to Division S. From the group's perspective, the cost of supplying these internally is ₹ 60 per unit (₹ 800 – ₹ 740) cheaper than buying externally. Division S's remaining demand of 5000 units should be bought from the external supplier at ₹ 800 per unit. Therefore, the **group's current policy will need to be changed**. In order to determine the transfer price which should be set for the internal sales of 30000 motors, the perspective of both divisions should be considered. Division M can only sell the motors to Division S and the lowest price it would be prepared to charge is the marginal cost of ₹ 740 of making these units but it will also wish to make a profit on each unit transferred. From Division S's perspective it can buy as many external motors as it needs from between ₹ 740 and ₹ 800. The total group profit will be the same irrespective of where in this range the transfer price is set outside the group at a price of ₹ 800 per unit so this will be the maximum price which it is prepared to pay. Therefore, **the transfer price should be set somewhere between ₹ 740 and ₹ 800**. The total group profit will be the same irrespective of where in this range the transfer price is set.

Q2 • Postal Test Paper, June'23 MTP Set 2

AB Ltd. Has two divisions Alfa & Beta. Alfa produces components, two units of which are required for one unit of final product produced by Beta. Alfa has a capacity to produce 20000 units and entire quantity is supplied to Beta @ ₹ 200 per unit. Variable cost component at Alfa is ₹ 190 & fixed cost ₹ 20 per unit. For final product of Beta, per unit variable cost excluding component is ₹ 700, fixed cost ₹ 200 and selling price is ₹ 1500.

Alfa has placed a proposal for increasing the transfer price to ₹ 220 i.e. the market price. Facility at Alfa can be rented out @ ₹ 3.00 Lacs p.a. Manager at Alfa wants to opt for this alternative

- Beta can buy this component from outside market @ ₹ 210
- If capacity of Alfa is augmented to 40000 units with an additional investment of ₹ 15 lacs, it can sell 20000 units to external market and balance to Beta @ ₹ 210 per unit. Fixed cost for Alfa will be up by ₹ 1.00 lac.

Evaluate and give your opinion under the following decision options.

- Facility of Alfa is rented out and Beta buys from market @ ₹ 210 per unit
- Alfa sells to outside market @ ₹ 220 and Beta buys @ 210 per unit from market
- Capacity enhancement with cost of capital @ 12 %

[8]

Reference
Evaluation and Opinion

What's **New**

Answer

Present position on transfer of component @ ₹ 200:

Particulars	Division Alfa	Division Beta
Units Sold	20000	10000
Selling Price/unit	₹ 200	₹ 1,500
Variable Cost/unit	₹ 190	₹ 1,100
Contribution /unit	₹ 10	₹ 400
Fixed Cost/unit	₹ 20	₹ 200
Profit /unit	₹ -10	₹ 200
Total Profit/Loss	₹ -2,00,000	₹ 20,00,000

Overall profit for the Company is ₹18,00,000.

a. Facility of Alfa is rented out and beta buys from market @ ₹ 210 per unit

Particulars	Division Alfa	Division Beta
Units Sold		10000
Selling Price/unit		₹ 1,500
Variable Cost/unit		₹ 1,120
Contribution /unit		₹ 380
Total Contribution		₹ 38,00,000
Fixed Cost		₹ 20,00,000
Rental Income	₹ 3,00,000	
Total Profit	₹ 3,00,000	₹ 18,00,000

Overall Profit for the Company is ₹ 21,00,000

b. Alfa sells to outside market @ ₹ 220 and Beta buys @ ₹ 210 per unit from market.

Particulars	Division Alfa	Division Beta
Units Sold	20000	10000
Selling Price/unit	₹ 220	₹ 1,500

Variable Cost/unit	₹ 190	₹ 1,120
Contribution /unit	₹ 30	₹ 380
Total Contribution	₹ 6,00,000	₹ 38,00,000
Fixed Cost	₹ 4,00,000	₹ 20,00,000
Total Profit	₹ 2,00,000	₹ 18,00,000

Overall Profit for the Company is ₹ 20,00,000

c. Capacity enhancement at the Cost of Capital @ 12 %

Particulars	Division Alfa (Sales)	Division Alfa (transfer)	Division Beta
Units Sold	20000	20000	10000
Selling Price/unit	₹220	₹ 210	₹ 1,500
Variable Cost/unit	₹190	₹ 190	₹ 1,120
Contribution /unit	₹30	₹ 20	₹ 380
Total Contribution	₹ 6,00,000	₹ 4,00,000	₹ 38,00,000
Fixed Cost	₹ 4,00,000	₹ 1,00,000	₹ 20,00,000
Cost of Capital		₹ 1,80,000	
Total Profit	₹2,00,000	₹ 1,20,000	₹ 18,00,000

Overall profit for the Company is ₹ 21,20,000.

Since overall profit is the highest in Option "C", it can be adopted.

Q3

Postal Test Paper

Your company fixes the inter-divisional transfer prices for its products on the basis of cost, plus a return on investment in the division. The Budget for Division A for 2021-22 appears as under:

Particulars	₹
Fixed Asset	5,00,000
Current Asset	3,00,000
Debtors	2,00,000
Annual Fixed cost of the division	8,00,000
Variable cost per unit of product	₹ 10 per unit
Budgeted Volume	4,00,000 units per year
Desired ROI	28%

Determine the transfer price for Division A.

[6]

Reference

What's **New****Transfer Price Based on ROI****Answer**

Particulars		₹
Variable Cost		10.00
Fixed Cost per unit	$8,00,000 \div 4,00,000$	2.00
Required Return	$\frac{10,00,000 \times 28\%}{4,00,000}$	0.70
Total cost or Transfer price		12.70

Q4**MTP Dec'23 Set 1**

A Company with two manufacturing divisions is organised on profit centre basis. Division 'A' is the only source for the supply of a component that is used in Division B in the manufacture of a product KLIM. One such part is used in each unit of the product KLIM. As the demand for the product is not steady. Division B can obtain orders for increased quantities only by spending more on sales promotion and by reducing the selling prices. The Manager of Division B has accordingly prepared the following forecast of sales quantities and selling prices.

Sales units per day	Average Selling price per unit of KLIM ₹
1,000	5.25
2,000	3.98
3,000	3.30
4,000	2.78
5,000	2.40
6,000	2.01

The manufacturing cost of KLIM in Division B is ₹3,750 for first 1,000 units and ₹750 per 1,000 units in excess of 1,000 units.

Division A incurs a total cost of ₹1,500 per day for an output to 1,000 components and the total costs will increase by ₹900 per day for every additional 1,000 components manufactured. The Manager of Division A states that the operating results of his Division will be optimised if the transfer price of the component is set at ₹1.20 per unit and he has accordingly set the aforesaid transfer price for his supplies of the component to Division B.

You are **required**:

- (a) **Prepare** a schedule showing the profitability at each level of output for Division A and Division B.
- (b) **Find** the profitability of the company as a whole at the output level which
 - (i) Division A's net profit is maximum.
 - (ii) Division B's net profit is maximum.
- (c) If the Company is not organised on profit centre basis, what level of output will be chosen to yield the maximum profit.

Reference

Divisional and Overall Profitability

What's New

Profit Centre & Cost Centre basis

Answer

- (i) **Statement showing profit of division A:**

Sale per day (units)	Sale value	Cost	Profit/(loss)
	₹	₹	₹
1,000	1,200	1,500	(300)
2,000	2,400	2,400	-
3,000	3,600	3,300	300
4,000	4,800	4,200	600
5,000	6,000	5,100	900
6,000	7,200	6,000	1,200

Profit of division B:

No of units	Sales	Transfer price	Other manufacturing cost	Total cost	Profit/(loss)
	₹	₹	₹	₹	₹
1,000	5,250	1,200	3,750	4,950	300
2,000	7,960	2,400	4,500	6,900	1,060
3,000	9,900	3,600	5,250	8,850	1,050
4,000	11,120	4,800	6,000	10,800	320
5,000	12,000	6,000	6,750	12,750	(750)
6,000	12,060	7,200	7,500	14,700	(2,640)

- (ii) **Profitability of the company at the output level where division A's net profit is maximum:**

	₹
Profit of division A at 6,000 units	1,200
Profit of division B at 6,000 units	(2,640)
Profit /(loss)	(1,440)
Division B's net profit is maximum:	
Profit of division A at 2,000 units	-
Profit of division B at 2,000 units	1,060
	1,060

- (c) **When the company is not organized on profit centre basis Profit at different levels of output**

Units	Division A	Division B	Total
	₹	₹	₹
1,000	(300)	300	—
2,000	—	1,060	1,060
3,000	300	1,050	1,350
4,000	600	320	920
5,000	900	(750)	150
6,000	1,200	(2,640)	(1,440)

Best output level is 3,000 units

Q5

June'23 MTP Set 1

SBA is a company that produces televisions and components for televisions. The company has two divisions, Division S and Division B. Division S manufactures components for televisions. Division S sells components to Division B and to external customers. Division B uses five of the components in each of the televisions that it manufactures, and sells televisions directly to external customers.

Division S

Budgeted Variable manufacturing cost per component	₹
Direct Material	14
Direct Labour	18
Variable Overhead	12

The following information relating to next year is also available

Fixed Cost	₹ 5,60,000
Production Capacity	175000 components
External demand	150000 components
Potential demand from Division B	80000 components
The anticipated external market price for a component is	₹ 50

Division B

Sales Price	₹ 450
Budgeted variable manufacturing cost per television	
Direct Material	₹ 40
Direct Labour	₹ 62
Variable overhead	₹ 16

In addition to the variable costs above, each television produced needs five components. Fixed costs are budgeted to be ₹14,60,000 for next year. Annual sales of televisions are expected to be 16,000 units.

Transfer pricing policy

Transfer prices are set at opportunity cost.

Division S must satisfy the demand of Division B before selling components externally.

Division B is allowed to purchase components from Division S or from external suppliers.

Required:

1. Assuming that Division B buys all the components it requires from Division S: **Produce** a profit statement for each division detailing sales and costs, showing external sales and internal company transfers separately where appropriate.
2. A specialist external supplier has approached Division B and offered to supply 80,000 components at a price of ₹42 each. The components fulfill the same function as those manufactured by Division S. The manager of Division B has accepted the offer and has agreed to buy all the components it requires from this supplier.

Develop and **submit** a revised profit statement for each division and for the total SBA company

3. **Discuss** the potential implications for SBA of outsourcing the production of one type of component that it manufactures

[8]

Reference

Transfer Pricing and Outsourcing

What's New

Answer

- (1) If Division B buys all of its components from division S (80000) then division S will sell its remaining capacity (95000) on the external market. This will result in unfulfilled demand of 55000 components (total demand of 150000 295000) in the external market. In terms of the transfer price 55000 of the components transferred will have an opportunity cost equal to the lost sales revenue of ₹ 50. This could be restated as variable cost (₹ 44) + lost contribution (₹ 6) giving a transfer price of ₹ 50. The remaining 25,000 units transferred to division B do not have an opportunity cost so the relevant cost is the marginal cost of ₹ 44. The profit statements will be as follows:

	S (₹)	B (₹)	Working
Sales			
Internal	38,50,000		1
External	47,50,000	72,00,000	2
	86,00,000	72,00,000	
Variable costs			
Components			
Internal	0		3
External	77,00,000		4
Other Variable	0	18,88,000	5
Fixed Costs	5,60,000	14,60,000	
Profit	3,40,000	2,000	

Workings:

- $(55,000 \times ₹ 50) + (25,000 \times ₹ 44) = ₹ 38,50,000$
- $95,000 \times ₹ 50 + ₹ 47,50,000$ Division S, $16,000 \times ₹ 450 = ₹ 72,00,000$
- Same as division S internal sales revenue
- $1,75,000 \times ₹ 44 = ₹ 77,00,000$
- $16,000 \times ₹ 118 = ₹ 18,88,000$

(2)

	S (₹)	B (₹)	SBA (₹)	Working
Sales				
Internal	0	0	0	

External	75,00,000	72,00,000	1,47,00,000	1
	75,00,000	72,00,000	1,47,00,000	
Variable costs				
Components				
Internal	0	0	0	
External	66,00,000	33,60,000	99,60,000	2
Other Variable	0	18,88,000	18,88,000	3
Fixed Costs	5,60,000	14,60,000	20,20,000	
Profit	3,40,000	4,92,000	8,32,000	

Workings:

- 1 Division S = 1,50,000 maximum external demand × ₹ 50;
division B = 16,000 × ₹ 450 = ₹ 72,00,000
 - 2 Division S = 1,50,000 × ₹ 44 variable cost = ₹ 66,00,000,
division B = 80,000 × ₹ 42 = ₹ 33,60,000
 - 3 16,000 × ₹ 118 = ₹ 18,88,000.
- (3) The motivation for **outsourcing** is that the external supplier may be able provides the component at a lower cost than SBA is currently incurring internally. Specialist component manufacturers may be more efficient arising from utilizing the latest manufacturing technology. The major disadvantage of outsourcing is that there is a **potential loss of control** and a danger that SBA will be at the mercy of the supplier when negotiating a new contract. This danger will be minimized if there are many other suppliers that can provide the component at a competitive price. A close relationship will be required between the two organizations requiring knowledge of lead times and the demand cycle at SBA. Outsourcing the manufacture of components may also result in spare capacity at SBA. Can this be utilized or can cost savings be achieved from reducing capacity?

	S (₹)	B (₹)	SBA (₹)	Working
Sales				
Internal	0	0	0	
External	75,00,000	72,00,000	1,47,00,000	1
	75,00,000	72,00,000	1,47,00,000	
Variable costs				
Components				
Internal	0	0	0	
External	66,00,000	33,60,000	99,60,000	2
Other Variable	0	18,88,000	18,88,000	3
Fixed Costs	5,60,000	14,60,000	20,20,000	
Profit	3,40,000	4,92,000	8,32,000	

Q6

Dec '23

Division A of DOXIN Ltd. has been given a budgeted target of selling 2,00,000 components TOM 22 it manufactures at a price which would fetch a return of 25% on the average assets employed by it. The following figures are relevant:

Fixed Overhead	₹ 4,00,000
Variable Cost	₹ 1 per unit
Average assets:	
Sales debtors	2,00,000
Stocks	6,00,000
Plant and other assets	4,00,000

However, the marketing department of the company finds out by a survey that the maximum number of TOM 22, the market can take, at the proposed price is only 1,40,000 units,

Fortunately, Division B is willing to purchase the balance 60,000 units. The Manager, the Manager, Division A is willing to sell to Division B at a concessional price of ₹ 4 per unit. But the manager Division B, is ready to pay ₹ 2.25 only per unit, as he feels he can himself in his Division at that price, make TOM 22 in his Division at that price.

Rather than sell to Division B at ₹ 2.25, the Manager, Division A, feels he will restrict the activity of his Division to the manufacture and sale of 1,40,000 components only. By this, he could reduce ₹ 80,000 in stocks, ₹ 1,20,000 of plant and other assets and ₹ 40,000 in selling and administration expenses (fixed in nature).

Required:

As a cost and management accountant, you are:

- (i) Asked to make comparative study of proposals of Divisional Manager and
- (ii) Justify that selling 60,000 TOM 22 to Division B at ₹ 2.25 per unit would be in the interest of the organization,

Reference

Comparative Study of Proposal

What's New

Answer

Sales price per unit		₹450
	Transfer to Division Band sale to outside parties	Sale to outside parties only
Sales (units)	2,00,000	1,40,000
	₹	₹
Sales value (140000 units)	6,30,000	6,30,000
(60000 units)	135000	Nil
	7,65,000	6,30,000
Less: Variable cost	2,00,000	1,40,000
Contribution	5,65,000	4,90,000
Less: Fixed overhead	4,00,000	3,60,000
Net profit	1,65,000	1,30,000
Average assets employed	12,00,000	2,80,000
Return on investment	13.75%	46.43%

Justification: If the component is transferred to Division B as well as sold to outside parties, it is more profitable as the contribution and net profit are more than the existing proposal. Therefore selling the components to Division B at ₹ 2,25 per unit is in the overall interest of the company is justified.

Q7

Dec '23

TECON LTD. (TL) a manufacturing company, sells its product at ₹ 1,200 per unit. Its competitors are likely to reduce the price by 20%. TL wants to respond aggressively by cutting price by 25% and expects that the present volume of 150000 units per annum will increase to 200000 units. TL wants to earn a 15% target profit on sales. Based on a detailed value engineering, the comparative position is given below:

Particulars	Existing (₹)	Target (₹)
Direct material cost per unit	425	400
Direct Labour cost per unit	65	60
Direct machinery cost per unit	80	70
Direct manufacturing expenses per unit	550	530
Manufacturing Overheads		
No of orders (₹ 80 per order)	23,000	22,000
Testing hours (₹ 2 per hour)	45,00,000	35,00,000
Units reworked (₹ 100)	13000	14400

Manufacturing overheads are allocated using relevant cost drivers. Other operating for the

expected volume are estimated as follows:

Research and Design	₹ 60
Marketing and Customer Service	₹ 124
	<u>₹ 184</u>

Required:

- (i) **Determine** target costs per unit and identify target costs for the proposed volume showing breakup of different elements.
- (ii) **Prepare** target product profitability statement. [7]

Reference Target Cost per unit, Target Product Profitability	What's New
---	-------------------

Answer

- (i) **Target Cost per unit ₹ 765**

The breakup of the target cost of ₹ 765 per unit is as follows:

	₹
Direct Materials	400
Direct Labour	60
Direct Machinery Costs	70
Direct Manufacturing Costs	530
Add : Manufacturing Overheads	51
Other Operating Costs	184
Full Product Costs	765

- (ii) **Target Product Profitability**

Particulars		Per Unit Total (₹)	Total for 200000 Unit (₹)
1.	Sales	900	180000000
2.	Cost of Goods Sold	581	116200000
3.	Gross Margin (1 - 2)	319	63800000
4.	Operating costs	184	36800000
5.	Operating Profit (3 - 4)	135	27000000

Decision Making using Probability

Q1

June'23 MTP Set 2

E Ltd manufactures a metal trimming device which has been sold at ₹ 16 per unit for a number of years. The selling price is to be reviewed and the following information is available on costs and likely demand. The standard variable cost of manufacture is ₹ 10 per unit and an analysis of the cost variances for the past 20 months show the following pattern which the production manager expects to continue in the future. Adverse variances of +10% of standard variable cost occurred in ten of the months. Nil variances occurred in six of the months. Favourable variances of -5% of standard variable cost occurred in four of the months. Monthly data Fixed costs have been ₹ 4 per unit on an average sales level of 20,000 units but these costs are expected to rise in the future and the following estimates have been made for the total fixed cost:

Monthly data Fixed costs have been ₹ 4 per unit on an average sales level of 20,000 units but these costs are expected to rise in the future and the following estimates have been made for the total fixed cost:

	₹
Optimistic estimate (Probability 0.3)	82,000
Most likely estimate (Probability 0.5)	85,000
Pessimistic estimate (Probability 0.2)	90,000

The demand estimates at the two new selling prices being considered are as follows:

If the selling price/unit is demand would be:	₹ 17	₹ 18
Optimistic estimate (Probability 0.2)	21 000 units	19 000 units
Most likely estimate (Probability 0.5)	19 000 units	17 500 units
Pessimistic estimate (Probability 0.3)	16 500 units	15 500 units

It can be assumed that all estimates and probabilities are independent.

You are **required** to

- (a) **Advise** management, based only on the information given above, whether they should alter the selling price and, if so, the price you would recommend;
- (b) **Calculate** the expected profit at the price you recommend and the resulting margin of safety, expressed as a percentage of expected sales;
- (c) **Criticize** the method of analysis you have used to deal with the probabilities given in the question;

(d) **Describe** briefly how computer assistance might improve the analysis.

[8]

Reference	What's New
Expected Profit	

Answer

- (a) For each of selling price there are three possible outcomes for sales demand, unit variable cost and fixed costs. Consequently, there are 27 possible outcomes. In order to present probability distributions for the two possible selling prices, it would be necessary to compute profits for 54 outcomes. Clearly, there would be insufficient time to perform these calculations within the examination time that can be calculations to be based on an **expected value approach**.

The expected value calculations are as follows:

(i) **Variable cost**

	₹
$\text{₹}(10 + \text{₹}10 \times 10\%) \times 10/20$	5.50
$\text{₹} 10 \times 6/20$	3.00
$\text{₹} (10 - 10 \times 5\%) \times 4/20$	1.90
	10.40

(ii) **Fixed cost**

	₹
$\text{₹} 82,000 \times 0.3$	24,600
$\text{₹} 85,000 \times 0.5$	42,500
$\text{₹} 90,000 \times 0.2$	18,000
	85,100

(iii) **₹ 17 selling price**

Particulars	Unit
21000 units \times 0.2	4,200
19000 units \times 0.5	9,500
16500 units \times 0.3	4,950
	18,650

(iv) **₹ 18 selling price**

Particulars	Unit
19000 units \times 0.2	3,800

17500 units × 0.5	8,750
15500 units × 0.3	4,650
	17,200

Expected contribution:

Selling price ₹17 = (₹ 17.00- ₹ 10.40) × 18,650 = ₹ 1,23,090

Selling price ₹ 18 = (₹ 18 - ₹ 10.40) × 17,200 = ₹ 1,30,720

The existing selling price is ₹ 16, and if demand continues at 20,000 units per annum then the total contribution will be 1120 [₹ (16 – 10.40) × 20,000 units] using the expected value approach, a selling price of ₹ 18 is recommended.

(b) Expected profit = ₹ 1,30,720 - ₹ 85,100 = ₹ 45,620 (fixed cost)

Break Even Point = Fixed cost /Contribution per unit

₹ 85,100/ ₹ 7.60 = 11,197 units

Margin of safety = expected demand (17,200 units) - 11,197 units = 6003 units

% margin of safety = 6003/17,200 = 34.9% of sales

Note that the most pessimistic estimate is above the break - even point.

- (c) An Expected Value approach has been used. The answer should draw attention to the limitations of basing the decision solely on expected values. In particular, it should be stressed that risk is ignored and the range of possible outcomes is not considered. The decision ought to be based on a comparison of the probability distributions for the proposed selling prices.
- (d) Computer assistance would enable a more complex analysis to be undertaken. In particular, different scenarios could be considered, based on different combinations of assumption regarding variable cost, fixed cost, selling prices and demand. Using computers would also enable the Monte Carlo simulation to be used for more complex decisions.

Q2

MTP Dec'23 Set 1; Postal Test Paper

A company has estimated the following demand level of its product:

Sales Volume (units)	10000	12000	14000	16000	18000
Probability	0.10	0.15	0.25	0.30	0.20

It has assumed that the sales price of ₹ 6 per unit, marginal cost of ₹ 3.50 per unit, and fixed costs of ₹ 34,000.

What is the probability that?

- (A) The company will break-even in the period?
 (B) The company will make a profit of at least ₹ 10,000?

[6]

Reference

Probability of break-even, making a profit

**What's New
Sales based**

Answer

(a) Probability of Break-even for the period

In order to break-even, the company must earn enough total contribution to cover its fixed costs. The contribution is ₹ 2.50 per unit (i.e.. 6 - 3.5).

Break-even Sales = (Fixed Cost ÷ Contribution per Unit)

$$= (34,000 \div 2.50) = 13,600 \text{ units}$$

Contribution required/ Contribution per unit = ₹ 34,000/₹2.50 = 13600 units

The probability that sales will equal or exceed 13,600 units is the probability that sales will be 14,000, 16,000 or 18,000 units which is $(0.25 + 0.30 + 0.20) = 0.75$ or 75%.

(b) Probability of earning Profit of ₹10,000

Contribution Needed = (Profit Needed + Fixed Cost)

$$= (10,000 + 34,000) = ₹44,000$$

Desired Sales = (Contribution Needed ÷ Contribution per Unit)

$$= (44,000 \div 2.50) = 17,600 \text{ units}$$

The probability that sales will equal or exceed 17,600 units is the probability that sales will be 18,000 units which is 0.20 or 20%

Every student is different

SJC HAS METHODS TO TEACH EVERY TYPE OF STUDENT

For Top-performing students Who are disciplined, sincere, and confident.

ONLY CLASSES

For self-disciplined, sincere, students who seek reassurance for improvement.

CLASSES + MOCK TEST

For students who needs a push to study with continuous evaluation system but have taken classes haphazardly

ONE STOP PASS SYSTEM

For students who start early & want to stay organized from day one

SURE SHOT BATCH

SCAN HERE

Become Our ROCKET STUDENT

Register for full group of any level of CA-CMA-CS & get the following **BENEFITS** :

- 01** 1 to 1 Preparation Assessment worth Rs. 2499/-
- 02** 10% OFF on Next Group Combo
- 03** 10% OFF on Group Mock Test Sangram (MTS)
- 04** 10% OFF on One Stop Passing System (OSPs)
- 05** 5% MONEY BACK for every Referral you give us

SCAN HERE

CA/CMA INTERNSHIP WORKSHOP

What we will cover?

- Importance of Internship?
- How it will help you in real world?
- How to start?
- Which area is good for you?

SCAN HERE

CA Girish Ganeriwala
CA Satish Jalan

FINANCE PRACTICAL TRAINING BASIC COURSE

Journey from Learning to Understanding

Grow yourself in any sphere by gaining the Confidence over the Numbers

SCAN HERE

CA Girish Ganeriwala
CA Satish Jalan

Activity Based Management and Just in Time (JIT)

4.1 Activity Based Costing

4.2 Just-in-Time (JIT)

4.3 Throughput Accounting

SJC Institute

Chapter 4.1

Activity Based Costing

Q1

Dec '23

ADF Bank operated for years under the assumption that profitability can be increased by increasing Rupee volumes. But that has not been the case. Cost analysis has revealed the following:-

Activity	Activity Cost (₹)	Activity Driver	Activity Capacity
Providing ATM Service	1,00,000	No. of transactions	2,00,000
Computer processing	10,00,000	No. of transactions	25,00,000
Issuing Statements	8,00,000	No. of statements	5,00,000
Customer inquiries	3,60,000	Telephone minutes	6,00,000

The following annual information on three products was also made available:

	Checking Accounts	Personal Loans	Gold Visa
Units of Product	30,000	5,000	10,000
ATM transactions	1,80,000	0	20,000
Computer transactions	20,00,000	2,00,000	3,00,000
Number of statements	3,00,000	50,000	1,50,000
Telephone minutes	3,50,000	90,000	1,60,000

Required:

- Calculate rates for each activity.
- Using the rates computed in requirement (i), assess the cost of each product. [7]



Reference

Rates for each Activity, Cost of each Product

What's **New**

Answer

Rates for each Activity

Activity	Activity Rate (₹)
Providing ATM Service	0.50

Computer Processing	0.40
Issuing Statements	1.60
Customer Inquiries	0.60

Cost of each Product

	Checking Accounts (₹)	Personal Loans (₹)	Gold VISA (₹)
Cost of each Product	52.67	42.80	46.60

SJC Institute

Chapter 4.2

Just In Time

Q1

June'23

PANIT LTD., a video company sells package of blank video tapes to its customers. It purchases video tapes from VISAN (I) Company @ ₹ 140 a packet. VISAN (I) Company pays all freight to PANIT LTD. No incoming inspection is necessary because VISAN (I) Company has a superb reputation for delivery of quality merchandise. Annual demand of PANIT LTD. is 13,000 packages. PANIT LTD. requires 15% annual return on investment. The purchase order lead time is two weeks. The purchase order is passed through internet and it costs ₹ 3 per order. The relevant insurance, material handling etc. ₹ 5.10 per package per year. PANIT LTD. has to decide whether or not to shift to JIT purchasing. VISAN (I) company agrees to deliver 100 packages of video tapes 130 times per year (5 times every two weeks) instead of existing delivery system of 1,000 packages 13 times a year, with additional amount of ₹ 0.50 per package. PANIT LTD. incurs no stock out under its current purchasing policy. It is estimated, PANIT LTD. incurs stock out cost on 50 video tape packages under a JIT purchasing policy. In the event of a stock out, PANIT LTD. has to rush order tape packages which costs ₹ 4 per package.

Required:

Assess the information as stated supra and advise PANIT LTD. as to whether it should implement JIT Purchasing system? [5]

Reference

JIT Purchasing System

What's New

Answer

	Normal	JIT
Purchase Cost (A × PP/ut)	1,30,000 × 140	1,30,000 × 140.5
TOC (No. of orders × Cost/order)	13 × 3	130 × 3
TCC ($\frac{Q}{2} \times (CC\% \times PP/ut + \text{other ccup.a.})$)	$\frac{1000}{2} \times (140 \times 15\% + 5.10)$	$\frac{100}{2} \times (140.5 \times 15\% + 5.10)$
Stock out cost	-	50 × 4
	18,33,089	18,28,399

Savings = 4,690

Throughput Accounting

Q1

MTP Dec'23 Set 1; Postal Test Paper

Modern Co produces 3 products, A, B and C, details of which are shown below:

Particulars	A	B	C
Selling price per unit (₹)	120	110	130
Direct material cost per unit (₹)	60	70	85
Variable overhead (₹)	30	20	15
Maximum demand (units)	30,000	25,000	40,000
Time required on the bottleneck resource (hours per unit)	5	4	3

There are 3,20,000 bottleneck hours available each month.

Required:

Calculate the optimum product mix based on the throughput concept.

[8]

Reference

Ranking & Allocation

What's New

Answer

Particulars	A	B	C
Selling price per unit (₹)	120	110	130
Direct material cost per unit (₹)	60	70	85
Throughput per unit (₹)	60	40	45
Time required on the bottleneck resource (hours per unit)	5	4	3
Return per factory hour (₹)	12	10	15
Ranking	2	3	1
Total Available hours	= 3,20,000		

(-) Hours used for C (40,000 x 3)	= 1,20,000	
(-) Hours used for A (30,000 x 5)	= 1,50,000	= 2,70,000
Balance hours available for B		= 50,000
No. of units that can be made in balance hours	= 50,000/4	= 12,500 units.

Statement showing optimum mix:

	A	B	C
No. of units	30,000	12,500	40,000

SJC Institute

Become Our **ROCKET STUDENT**

Register for **full group** of any level of **CA-CMA-CS** & get the following **BENEFITS**:

01

1 to 1 Preparation Assessment worth **Rs. 2499/-**

02

10% OFF on Next Group Combo

03

10% OFF on Group Mock Test Sangram (MTS)

04

10% OFF on One Stop Passing System (OSPS)

05

5% MONEY BACK for every Referral you give us

- You may choose from **any faculties** on SJC Website
- If you have registered only one subject, then you may register other subjects of the same group **within 15 days** to claim these benefits

Please connect with us at **8100 11 2222** with your registration details to know more



Evaluating Performance - Variance Analysis

Q1

June'23 MTP Set 1

You have been provided with the following data for S plc for September:

Accounting method: Variances	Absorption (₹)	Marginal (₹)
Selling Price	1,900 (A)	1,900 (A)
Sales Volume	4,500 (A)	7,500 (A)
Fixed overhead expenditure	2,500 (F)	2,500 (F)
Fixed overhead volume	1,800 (A)	n/a

During September production and sales volumes were as follows:

	Sales	Production
Budget	10000	10000
Actual	9500	9700

Required:

- a) **Calculate:**
 - (i) the standard contribution per unit;
 - (ii) the standard profit per unit;
 - (iii) the actual fixed overhead cost total.
- b) Using the information presented above, **analyze** how different variances are calculated on the basis of the choice of marginal or absorption costing. [6 + 2 = 8]

<p>Reference</p> <p>Different Variances - Marginal or Absorption Costing</p>	<p>What's New</p>
--	--------------------------

Answer

a. (i) Sales margin variance (Marginal costing):

$$\begin{aligned} & (\text{Actual Volume} - \text{Budgeted Volume}) \times \text{Standard Contribution Margin} \\ & = (9500 - 10000) \times \text{Standard Contribution Margin (SCM)} = ₹ 7,500 \text{ (A)} \\ & 500 \text{ SCM} = ₹ 7,500 \text{ (A)} \end{aligned}$$

Therefore, SCM (Standard Contribution Margin) = ₹ 15

(ii) Sales margin volume variance (Absorption Costing)

$$\begin{aligned} & (\text{Actual Volume} - \text{Budgeted Volume}) \times \text{Standard profit margin per unit} \\ & = (9500 - 10000) \times \text{Standard Profit Margin (SPM)} = ₹ 4,500 \text{ (A)} \\ & 500 \text{ SPM} = ₹ 4,500 \text{ (A)} \end{aligned}$$

SPM (Standard Profit Margin) = ₹ 9

(iii) Fixed Overhead Volume Variance

$$\begin{aligned} & (\text{Actual Production} - \text{Budgeted Production}) \times \text{Standard Rate} \\ & = (9700 - 10000) \times \text{Standard Rate} = ₹ 1,800 \text{ (A)} \end{aligned}$$

Standard Fixed Overhead rate per unit = ₹ 6

Budgeted Fixed Overheads = 10000 units \times ₹ 6 = ₹ 60,000

Fixed Overhead expenditure variance = ₹ 2,500 (F)

Actual Fixed Overheads (₹ 60,000 - ₹ 2,500) = ₹ 57,500.

- b.** Absorption costing unitises fixed overheads and treats them as product costs whereas marginal costing does not charge fixed overheads to products. Instead, the total amount of fixed overheads is charged as an expense (period cost) for the period. A fixed overhead volume variance only occurs with an absorption costing system. Because marginal costing does not unitise fixed costs product margins are expressed as contribution margins whereas absorption costing expresses margins as profit margins.

Q2

June'23 MTP Set 1

From past experience a company operating a standard cost system has accumulated the following information in relation to variances in its monthly management accounts:

Percentage of total number of variances

1. Its variances fall into two categories:

Category 1: those that are not worth investigating	64%
Category 2: those that are worth investigating	36%
	100%

- Of Category 2, corrective action has eliminated 70 per cent of the variances, but the remainder have continued.
- The cost of investigation averages ₹350 and that of correcting variances averages ₹550.
- The average size of any variance not corrected is ₹525 per month and the company's policy is to assess the present value of such costs at 2% per month for a period of five months.

You are **required** to prepare two decision trees, to represent the position if an investigation is

- carried out;
- not carried out.

[2 + 2 = 4]

Reference | **What's New**

Decision Tree - Investigation of Variances

Answer

Decision Tree if an investigation is carried out

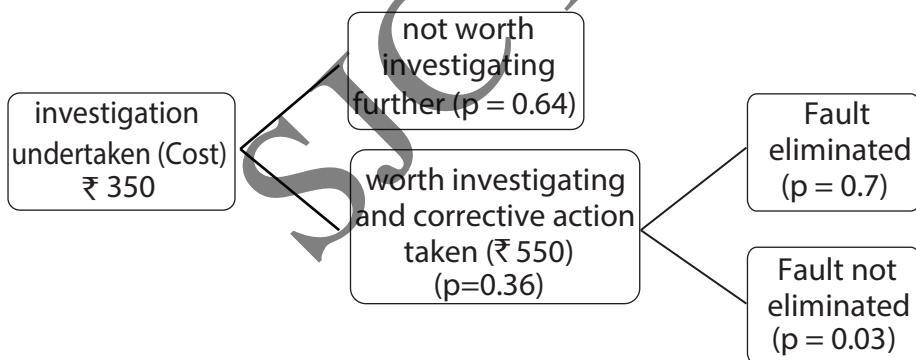

It is assumed that the ₹ 550 correction cost applies to all variances that the initial investigation indicates are worthy of further investigation. The expected cost if the investigation is carried out is -

$$₹ 350 + ₹ 550 \text{ (corrective action)} + 0.36 \times 0.3 \times ₹ 246 \text{ (continuing variance)} = ₹ 815$$

[**Note:** ₹ 246 represents the PV of ₹ 525 for 5 month at 2% (₹ 525 × 4.7135) for variances that are not eliminated]

Decision Tree if an investigation is not carried out

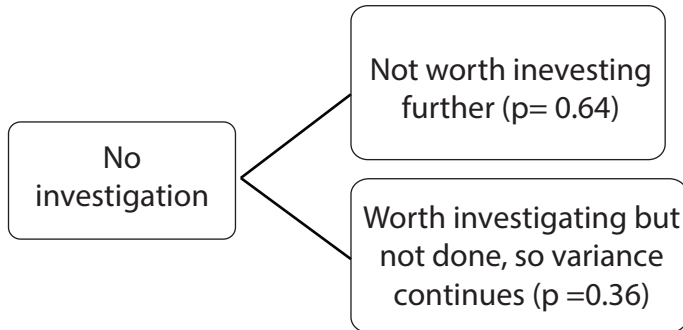

The expected cost if no investigation is undertaken is

$$0.36 \times ₹ 525 \times 4.7135 = ₹ 891.$$

Q3

June'23 MTP Set 2

The summarized results of a company for the two years ended 31st December 2021 and 2022 are given below:

	2021 (₹ in Lakhs)	2022 (₹ in Lakhs)
Direct Materials	324	300
Sales	770	600
Direct Wages	137	120
Variable Overheads	69	60
Fixed Overheads	150	80
Profit	90	40

As a result of re-organization of production methods and extensive advertisement campaign, the company was able to secure an increase in the selling prices by 10% during the year 2022 as compared to the previous year.

In the year 2022, the company consumed 1,20,000 Kgs. of raw materials and used 24,00,000 hours of direct labour. In the year 2023, the corresponding figures were 1,35,000 kgs of raw materials and 26,00,000 hours of direct labour.

You are **required** to:

Use information given for the year 2022 as the base year information to analyze the results of the year 2023 and to show in a form suitable to the management the amount each factor has contributed by way of price, usage and volume to the change in profit in 2023. [8]

Reference	What's New
Profit Reconciliation Statement	

Answer

A. Sales Variance

- Sales price variance = ₹ 770 – (₹ 770 × 100/110) – ₹ 600 = ₹ 70 (F)
- Sales Volume Variance = ₹(770 × 100/110) – ₹ 600 = ₹ 100 (F)
% increase in volume = (100/600) × 100 = ₹ 16.67%
- Sales value variance = ₹ 770 – ₹ 600 = ₹ 170 (F)

B. Material Variance

Material price = (300,00,000)/120000 = ₹ 250/-

Material expected to be used = (120000/600) × 700 = 140000 kgs

Standard Material Cost = 140000 × ₹ 250 = ₹ 350 lacs

- Material Cost variance = ₹(350 – 324) = ₹ 26
- Material volume variance = 300 × 1/6 = ₹ 50 (A)
- Material usage variance = 5000 × ₹ 250 = ₹ 12,50,000(F)
- Material price variance = ₹(250 – 240) × 135000 = ₹ 13,50,000 (F)

C. Labour Variance

Labour hours expected to be used = (24,00,000/600) × 700 = 28,00,000

Labour rate = (120,00,000)/24,00,000 = ₹ 5

Standard labour cost = 28,00,000 × ₹ 5 = ₹ 140 lacs

- Labour cost variance = ₹ 140 – ₹ 137 = ₹ 3 (F)
- Labour volume variance = 120/6 = ₹ 20 (A)
- Labour efficiency variance = 2 × ₹ 5 = ₹ 10 (F)
- Labour rate variance = ₹ (20 – 3 – 10) = ₹ 7 (A)

D. Overhead Variance

Standard variance overheads = ₹ 60 + (₹ 60 × 16.67 %) = ₹ 70

Standard variable overhead rate per hour = ₹ 60/24 = ₹ 2.5

- VOH Cost variance = ₹ (70 – 69) = ₹ 1 (F)
- VOH volume variance = ₹ 60/6 = ₹ 10 (A)
- VOH efficiency variance = (2800000 – 2600000) × ₹ 2.5 = ₹ 5 (F)
- VOH expenditure variance = ₹ (10 – 1 – 5) = ₹ 4 (A)

16. FOH cost variance = ₹ 70 (A)

Profit Reconciliation Statement:

Particulars	₹ in lakhs	₹ in lakhs
Profit for 2022		40
(+) Sales Variance :		
Price	70	
Volume	100	
Material Variance :		
Usage	12.50	
Price	13.50	
(-) Material volume variance	50	
Labour variance – efficiency	10	
Labour Variance :		
Volume	20	
Rate	7	
VOH Variances:		
VOH efficiency variance	5	211
		251
Volume	10	
Expenditure	4	
FOH cost variance :	70	161
Profit for 2023		90

Q4

June'23 MTP Set 2

At the beginning of 2023, ASA Inc. set a standard marginal cost for its major product of ₹ 25 per unit. The standard cost is recalculated once each year. Actual production costs during August 2023 were ₹ 3,04,000, when 8,000 units were made. With the benefit of hindsight, the management of ASA Inc. realizes that a more realistic standard cost for current conditions would be ₹ 40 per unit. The planned standard cost of ₹ 25 is unrealistically low.

Required

- (i) **Calculate** the planning and operational variances.
- (ii) **What** is the implication of planning and operational variances against traditional variance? **State** your answer in particular reference to the information given in the above situation. [4]

Reference	What's New
Planning and Operational Variances	

Answer

- (i) With the benefit of hindsight, the realistic standard should have been ₹ 40. The variance caused by favourable or adverse operating performance should be calculated by comparing actual results against this realistic standard.

	₹
Revised standard cost of actual production (8,000 × ₹ 40)	3,20,000
Actual cost	3,04,000
Total operational variance	16,000 (F)

The variance is favourable because the actual cost was lower than would have been expected using the revised basis. The planning variance reveals the extent to which the original standard was at fault.

		₹
Revised standard cost	8,000 units × ₹ 40 per unit	320,000
Original standard cost	8,000 units × ₹ 25 per unit	200,000
Planning variance		120,000 (A)

It is an adverse variance because the original standard was too optimistic, overestimating the expected profits by understating the standard cost. More simply, it is adverse because the revised cost is much higher than the original cost.

	₹
Planning variance	120,000 (A)
Operational variance	16,000 (F)
Total	104,000 (A)

- (ii) If traditional variance analysis had been used, the total cost variance would have been the same, but all the blame would appear to lie on actual results and operating inefficiencies (rather than some being due to faulty planning).

	₹
Standard cost of 8000 units × ₹ 25 per unit	2,00,000
Actual cost of 8000 units	3,04,000
Total cost variance	1,04,000 (A)

Q5

June'23

SUZIN LTD. using a detailed system of standard costing finds that the cost of investigation of variances is ₹ 20,000. If after investigation an out of control situation is discovered, the cost of correction is ₹ 30,000. If no investigation is made, the present value of extra cost involved is ₹ 1,50,000. The probability of the process being in control is 0.82 and the probability of the process being out of control is 0.18.

You are **required** to advise:

- (I) **Whether** investigation of the variances should be undertaken or not
- (II) the probability at **which** it is desirable to institute investigation into variance. [4]

Reference	What's New
Evaluation of Investigation of Variances	Profitability Calculation

Answer

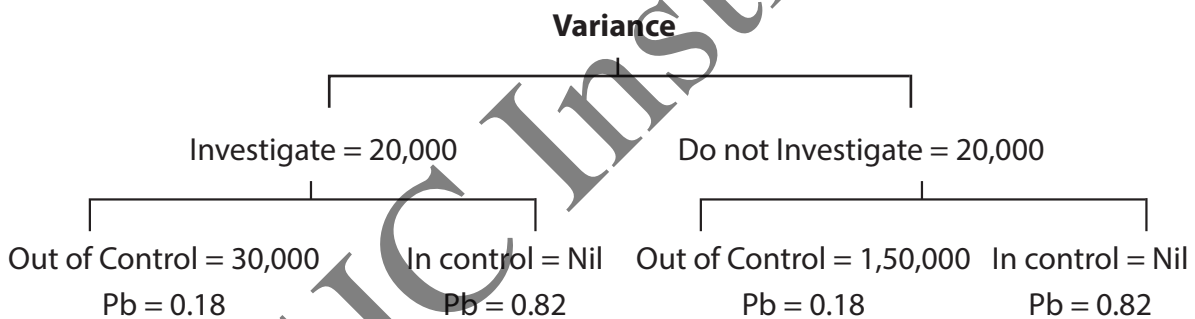

Expected Cost of Investigate = $(20,000 + 30,000) \times 0.18 + 20,000 \times 0.82$

Exp = 25,400

Expected Cost of No Investigate = $1,50,000 \times 0.18 = 27,000$

∴ Investigate.

Pb : Indifference

$$50,000 \times P + 20,000 \times (1 - P) = 1,50,000 \times P$$

$$50,000P + 20,000 - 20,000P = 1,50,000P$$

$$1,20,000P = 20,000$$

$$P = \frac{20}{120} = \frac{1}{6} = 16.67\%$$

Pb of out of control = 16.67% or higher, these only investigate.

Q6

June'23 MTP Set 2

Director-Operations of ABC Ltd. (ABCL) is of the view that Standard Costing has little to offer in the reporting of material variances due to frequently change in price of materials.

ABCL can utilize one of two equally suitable raw materials and always plan to utilize the raw material which will lead to cheapest total production costs. However ABCL is frequently trapped by price changes and the material actually used often provides, after the event, to have been more expensive than the alternative which was originally rejected.

During last accounting period, to produce a unit of 'Gama', ABCL could use either 5 kg. of 'Exe' or 5 kg. of 'Wye'. ABCL planned to use 'Exe' as it appeared it would be cheaper of the two and plans were based on a cost of 'Exe' of ₹ 3 per kg. Due to market movements the actual price changed and if ABCL had purchased efficiently the cost would have been:

'Exe' ₹ 4.50 per kg

'Wye' ₹ 4 per kg

Production of 'Gama' 1,000 units and usage of 'Exe' amounted to 5,400 kg at a total cost of ₹ 25,920.

Calculate the material variance for 'Gama' by:

- (i) Traditional variance analysis and
- (ii) An approach which distinguishes between Planning and Operational Variances. [8]

Reference

Material Variances - Planning, Operational & Traditional Variances

What's New

Answer

Planning				Operating							
Original Standard for AO			Rev Standard for AO	Act							
	Q	R	A		Q	R	A		Q	R	A
Exe	5,000	3	15,000	Exe	5,000	4.50	22,500	Exe	5,400	4.8	25,920
WYe	5,000	?	?	WYe	5,000	4	?	WYe			

Traditional : MCV = 15,000 – 25,920 = 10,920 A
 Original Std vs Act MPV = (3 – 4.8) × 5,400 = 9,720 A
 MUV = (5,000 – 5,400) × 3 = 1,200 A

Planning : $MCV = 15,000 - 22,500 = 7,500 \text{ A}$

Original Std vs Act $MPV = \text{Uncontrollable} = (3 - 4) \times 5,000 = 5,000 \text{ A}$

$MUV = \text{Controllable} = (4 - 4.5) \times 5,000 = 2,500 \text{ A}$

7,500 A

Operational : $MCV = 22,500 - 25,920 = 3,420 \text{ A}$

Original Std vs Rev Std $MPV = (4.50 - 4.8) \times 5,400 = 1,620 \text{ A}$

$MUV = (5,000 - 5,400) \times 4.5 = 1,800 \text{ A}$

Q7

MTP Dec'23 Set 1

S.V. Ltd. manufactures BXE by mixing three raw materials. For every batch of 100Kg. of BXE, 125 Kg. of raw materials are used. In April 2021, 60 batches were prepared to produce an output of 5,600 Kg. of BXE. The standard and actual particulars for April 2021 are as under:

Raw material	Standard		Actual		Quantity of raw materials purchased kg
	Mix %	Price per kg	Mix %	Price per kg	
A	50	20	60	21	5,000
B	30	10	20	8	2,000
C	20	5	20	6	1,200

Calculate relevant material variances.

[7]

Reference

Material Variances

What's New

Processing Loss

Answer

Standard Production = (60 batches \times 100 units per batch) = 6,000 units

Standard Raw Material for 6,000 units = (60 batches \times 125 kg) = 7,500 kg

Standard Loss = (7,500 - 6,000) = 1,500 kg

Actual Production = 5,600 units

Standard Mix for 60 batches (i.e., 6,000 units)

Raw Material	Mix (%)	Quantity (Kg)	Price (₹)	Value (₹)
A	50	3,750	20	75,000
B	30	2,250	10	22,500

C	20	1,500	5	7,500
Total		7,500		1,05,000
Standard Loss @ 25 kg per batch	60 × 25 = 1,500			
Production		6,000		1,05,000

Standard Mix for Actual Production of 5,600 units

Raw Material	Mix (%)	Quantity (Kg)	Standard Price (₹)	Value (₹)
A	50	3,500	20	70,000
B	30	2,100	10	21,000
C	20	1,400	5	7,000
Total		7,000		98,000

Actual Mix for 5,600 units

Raw Material	Mix (%)	Quantity (Kg)	Standard Price (₹)	Actual Price (₹)	Standard Value (₹)	Actual Value (₹)
A	60	4,500	20	21	90,000	94,500
B	20	1,500	10	8	15,000	12,000
C	20	1,500	5	6	7,500	9,000
Total		7,500			1,12,500	1,15,500
Actual Loss = 7,500 – 5600		1,900				
Production		5,600			1,12,500	1,15,500

Note:

Purchased quantity is 8,200 kg; but consumed quantity is only 7,500 kg.

Material Cost Variance = Standard Cost – Actual Cost = 98,000 – 1,15,500 = ₹ 17,500 (A)

Material Price Variance = AQ (SP – AP) = (1,12,500 – 1,15,500) = ₹ 3,000 (A)

Material Yield Variance = (Standard Price of Standard Mix for Actual Production – Standard Price of Standard Mix for Standard Production)

$$= (98,000 – 1,05,000) = ₹ 7,000 (A)$$

Material Mix Variance = Standard Price of Standard Mix for Standard Production – Standard Price of Actual Mix for Actual Production

$$= (1,05,000 – 1,12,500) = ₹ 7,500 (A)$$



MTP Dec'23 Set 1

Vinak Ltd. has furnished you the following information for the month of February, 2017.

	Budget	Actual
Output (Units)	30,000	32,500
Hours	30,000	33,000
Fixed Overhead	₹45,000	₹ 50,000
Variable overhead	60,000	68,000
Working days	25	26

Calculate Variances.

[7]

Reference

What's New

Variable OH & Fixed OH Variances

Answer

Calculation of Fixed OH Variances using hourly rate:

SRSH (1)	SRAH (2)	SRRBH (3)	SRBH (4)	ARAH (5)
1.5×32500	1.5×33000	1.5×31200		
48750	49500	46800	45000	50000

$$SR = \frac{BFO}{BH} = \frac{45,000}{30,000} = 1.5$$

$$RBH \quad 25 \text{ ----- } 30000$$

$$26 \text{ ----- } ?$$

$$SH \quad 30000 \text{ ----- } 30000$$

$$32500 \text{ ----- } ?$$

Fixed Overhead Efficiency Variance : 1 – 2 = 750 (A)

Fixed Overhead Capacity Variance : 2 – 3 = 2700

Fixed Overhead Calendar Variance : 3 – 4 = 1800

Fixed Overhead Volume Variance : 1 – 4 = 3750

Fixed Overhead Budget Exp. Variance: 4 – 5 = 5000 (A)

Fixed Overhead Cost Variance: 1 – 5 = 1250(A)

Calculation of Variable OH's Variance:

SRSH (1)	SRAH (2)	ARAH (3)
2 × 32500	2 × 33000	
65000	66000	68000

$$SR = \frac{BVOH}{BH's} = \frac{60,000}{30,000} = 2$$

SRSH = Std. Cost of Std. Variable Overhead's

SRAH = Atd Cost of Actual Variable Overhead's

ARAH = Actual Cost of actual Variable Overhead's

- A) Variable Overhead Efficiency Variance 1 – 2 = 1000 (A)
- B) Variable Overhead Budget/Exp Variance 2 – 3 = 2000 (A)
- C) Variable Overhead Cost Variance 1 – 3 = 3000 (A)

Q9

Dec '23

DOTSON Ltd. has a manufacturing division which makes a product to which the following details relate:

	Per unit ₹
Direct Material: 5 kg at ₹ 20	100
Direct labour: 12 hours at ₹ 20	240
Variable overheads: 12 hours at ₹ 10	120

Relevant fixed overheads are based at ₹ 1,00,000 per month and planned output is 2,000 units per month. The selling price is ₹ 550 per unit. During a recent month, when output was 1,800 units, the following actual cost were incurred.

	₹
Direct materials (8,500 kg)	1,72,000
Direct labour (20,000 hours)	4,20,000
Variable overhead	2,20,000
Fixed overhead	98,000
	9,10,000
Profit	40,000
Sales Value	9,50,000

Required :

- (a) **Analyse** the variances which occurred during the month.
- (b) **Reconcile** the actual profit with standard profit, showing the causes of differences. [14]

Answer

(a) Computation of Variance

- (1) Material Price Variance = 2000 (Adv)
- (i) Material Usage Variance = 10000 (FAV)
- (iii) Wage Usage Variance = 20000 (Adv)
- (iv) Wage Efficiency Variance = 32000 (Fav)
- (v) Variable Overhead expenditure Variance = 20000 (Adv)
- (vi) Variable overhead efficiency Variance = 16000 (Fav)
- (vii) Fixed overhead expenditure Variance = 2000 (Fav)
- (viii) Fixed overhead Capacity Variance = 16667 (Adv)
- (ix) Fixed overhead efficiency Variance = 6667 (Fav)
- (x) Sales Margin price Variance = 40000 (Adv)
- (xi) Sales Margin Volume variance = 8000 (Adv)

(b) Reconciliation of Profit.

	₹
Budgeted Profit	80000
Add: Favorable Variances:	66667
Less: Adverse variances:	(106667)
Actual Profit (for the period):	40000

One-Stop Pass System

For students who needs a push to study with continuous evaluation system but have taken classes haphazardly

SCAN HERE



Sure Shot Batch

आप बस पढाई कीजिए
पूरी PLANNING हमारी

SCAN HERE



BOUNCE BACK ASSESSMENT

To Bounce Back you need to do something different. But what? Take our Bounceback Assessment to know.

SCAN HERE



PREPARATION ASSESSMENT

Know whether you are
on the right track

SCAN HERE



Mock test Sangram

The more you sweat in practice, the less you bleed in Battle

SCAN HERE



Rankers Batch

Are you aiming for a
top rank in exams?
Join our Rankers Batch

SCAN HERE



Chapter 6 Linear Programming

Q 1

June'23 MTP Set 1

An animal feed company must produce 200 kg. of a mixture consisting of ingredients X_1 and X_2 . The ingredient X_1 cost ₹ 3 per kg. and X_2 cost ₹ 5 per kg. Not more than 80 kg. of X_1 can be used and at least 60 kg. of X_2 must be used. **Find** the minimum cost mixture, using LP technique. [6]



Reference

Minimum Cost Mixture - Graphical Solution

What's New

Answer

The appropriate mathematical formulation of the given problem as LP model is as follows:

$$\text{Minimize (total cost)} = 3x_1 + 5x_2$$

Subject to the constraints

$$x_1 + x_2 = 200, x_1 \leq 80, x_2 \geq 60,$$

$$x_1 \geq 0 \text{ and } x_2 \geq 0$$

Drawing the lines $x_1 + x_2 = 200$, $x_1 = 80$ and $x_2 = 60$ on a graph sheet, we get the adjoining figure.

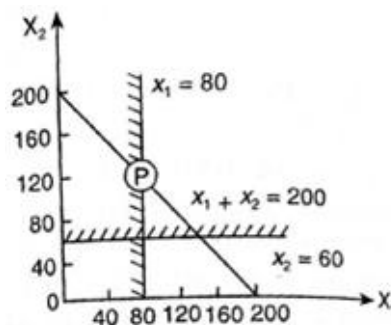

It may be observed from the adjoining figure that the given problem has no feasible solution space (shaded area) but has only one feasible point with its co-ordinates $x_1 = 80$ and $x_2 = 120$. Hence the optimum solution is to mix 80 kgs. of ingredients X_1 and 120 kgs. of ingredients X_2 to have a minimum cost of ₹ 840.

Q2

June'23 MTP Set 2

Write the dual of the following linear programming problem:

$$\text{Minimize } Z = 5x_1 - 6x_2 + 4x_3$$

Subject to the constraints

$$3x_1 + 4x_2 + 6x_3 \geq 9$$

$$x_1 + 3x_2 + 2x_3 \geq 5$$

$$7x_1 - 2x_2 - x_3 \leq 10$$

$$x_1 - 2x_2 + 4x_3 \geq 4$$

$$2x_1 + 5x_2 - 3x_3 = 3$$

$$x_1 \geq 0, x_2 \geq 0, x_3 \geq 0$$

[7]

Reference

What's New

Formulation of Dual

Answer

First, we convert the equality constraint in terms of two inequalities, one involving ' \leq ' by (-1). Then the primal problem can be written as follows:

$$\text{Minimize } Zx = 5x_1 - 6x_2 + 4x_3$$

Subject to the constraints

$$3x_1 + 4x_2 + 6x_3 \geq 9$$

$$x_1 + 3x_2 + 2x_3 \geq 5$$

$$-7x_1 + 2x_2 + x_3 \geq -10$$

$$x_1 - 2x_2 + 4x_3 \geq 4$$

$$2x_1 + 5x_2 + 3x_3 \geq 3$$

$$-2x_1 - 5x_2 + 3x_3 \geq -3$$

$$x_1, x_2, x_3 \geq 0$$

Let y_1, y_2, y_3, y_4, y_5 and y_6 be the dual variables corresponding to the six constraints in given order, then the dual of the given primal problem can be formulated as follows:

$$\text{Maximize } Z_y = 9y_1 + 5y_2 - 10y_3 + 4y_4 + 3y_5 - 3y_6$$

Subject to the constraints

$$3y_1 + y_2 - 7y_3 + y_4 + 2y_5 - 2y_6 \leq 5$$

$$4y_1 + 3y_2 + 2y_3 - 2y_4 + 5y_5 - 5y_6 \leq -6$$

$$6y_1 + 2y_2 + y_3 + 4y_4 - 3y_5 + 3y_6 \leq 4$$

$$y_1, y_2, y_3, y_4, y_5, y_6 \geq 0$$

Let $y_7 = y_5 - y_6$, then the above dual problem reduces to the form:

$$\text{Maximize } Z_y = 9y_1 + 5y_2 - 10y_3 + 4y_4 + 3y_7$$

Subject to the constraints

$$3y_1 + y_2 - 7y_3 + y_4 + 2y_7 \leq 5$$

$$-4y_1 - 3y_2 - 2y_3 + 2y_4 - 5y_7 \geq 6$$

$$6y_1 + 2y_2 + y_3 + 4y_4 - 3y_7 \leq 4$$

$$y_1, y_3, y_3, y_4 \geq 0 \text{ and } y_7 \text{ is unrestricted in sign.}$$

Q3

June'23

UTKARSH Bank is in the process of formulating its loan policy involving a maximum of ₹ 600 million. Table below gives the relevant types of loans. Bad debts are not recoverable and produce no interest revenue. To meet competition from other banks, the following policy guidelines have been set. At least 40% of the funds must be allocated to the Agricultural and Commercial loans. Funds allocated to Housing must be at least 50% of all loans given to personal, car, housing. The overall bad debts on all loans may not exceed 0.06.

Type of Loan	Interest Rate (%)	Bad Debt (Probability)
Personal	17	0.10
Car	14	0.07
Housing	11	0.05
Agricultural	10	0.08
Commercial	13	0.06

Required:

Develop and formulate a linear programming model to determine optimal loan allocation. [6]



Reference

Formulation of LP

What's New

Answer

Maximise $Z = 0.17x_1 + 0.14x_2 + \dots$

Subjected to :

Total Loan = $x_1 + x_2 + \dots \leq 600$

Agriculture and Commercial = $x_4 + x_5 \geq 0.4(x_1 + x_2 + x_3 + x_4 + x_5)$

Housing = $x_3 \geq 0.5(x_1 + x_2 + x_3)$

Bad debt = $0.10x_1 + 0.07x_2 + 0.05x_3 + 0.08x_4 + 0.06x_5 \leq 0.06(x_1 + x_2 + x_3 + x_4 + x_5 + x_6)$

NNA \Rightarrow

$x_1 \geq 0.10$

$i = 1-6$

Q4

MTP Dec'23 Set 1

Mr. Lal is on a low cholesterol diet. During lunch at the office canteen he always chooses between two particular types of meal – Type A and Type B. The table below lists the amount of protein, carbohydrates and vitamins each meal provides along with the amount of cholesterol (which he is trying to minimize). He needs at least 200 grams of protein, 960 grams of carbohydrates and 40 grams of vitamins for lunch each month. Over this time period, how many days should he have Type A meal and how many days the Type B meal so that he gets adequate amount of protein, carbohydrates and vitamins and at the same time minimizes his cholesterol intake? Use Graphical Method.

	Type A meal	Type B meal
Protein (Grams)	8	16
Carbohydrates (Grams)	60	40
Vitamins (Grams)	2	2
Cholesterol (Miligrams)	60	50

Reference

Formulation and Solution of LPP

What's New

Graphically

Answer

Let, x = No. of days Mr. Lal will take Type A meal & y = No. of days Mr. Lal will take Type B meal
 Since the goal is to minimize Mr. Lal's cholesterol intake, the Objective Function should repre-

sent the total cholesterol provided by both the meals.

So the Objective Function is $Z = 60x + 50y$ The constraints are given as follows –

$8x + 16y \geq 200$ (Constraint associated with the total protein provided by the two types of meals) Or, $x + 2y \geq 25$

$60x + 40y \geq 960$ (Constraint associated with the total carbohydrates provided by the two types of meals)

Or. $3x + 2y \geq 48$

$2x + 2y \geq 40$ (Constraint associated with the total vitamins provided by the two types of meals)
Or, $x + y \geq 20$

Also x and y being number of days cannot be negative i.e $x \geq 0$ and $y \geq 0$ So the formulated LPP can be stated as –

Minimize $Z = 60x + 50y$ Subject to the constraints $x + 2y \geq 25$

$3x + 2y \geq 48$ $x + y \geq 20$

$x \geq 0$ and $y \geq 0$

To find the feasible region, first of all the straight lines corresponding to the above constraints are drawn using the method followed in the previous illustration.

$x + 2y = 25$ Or, $x/25 + y/12.5 = 1$ is the first constraint line and it passes through (25,0) and (0,12.5)

$3x + 2y = 48$ Or, $x/16 + y/24 = 1$ is the second constraint line which passes through (16,0) and (0,24)

$x + y = 20$ Or, $x/20 + y/20 = 1$ is the third constraint line and it passes through (20,0) and (0,20)
 $x = 0$ is the axis of y and $y = 0$ is the axis of x

Now the constraint inequalities are graphed and the common region of the same is shaded as shown in the diagram below. It can be mentioned that the region of feasibility in this case is unbounded on the upper side. But that is not a matter of concern because the problem deals with minimization of the Objective Function which is confined to the corner points of the lower boundary of the envelope. As per the diagram, such corner points are A, B, C and D. Of these points coordinates of A and D are directly available from the graph because they lie on the axes. Coordinates of C and D can also be obtained from the graph. But it is suggested to get those by solving the simultaneous equations.

Coordinates of B is obtained by solving the equations $3x + 2y = 48$ and $x + y = 20$ and those of C is obtained by solving $x + y = 20$ and $x + 2y = 25$

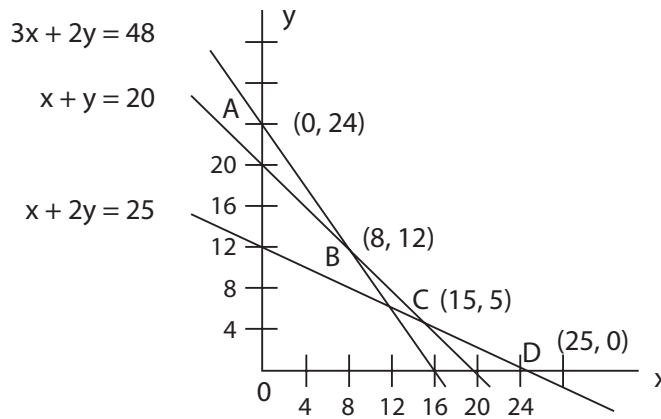

Now the value of the Objective Function is computed at each of the corner points and shown in the table below.

Coordinates of the Corner Point	Value of the Objective Function ($Z = 60x + 50y$)
A (0,24)	$60 \cdot 0 + 50 \cdot 24 = 1200$
B (8,12)	$60 \cdot 8 + 50 \cdot 12 = 1080$
C (15,5)	$60 \cdot 15 + 50 \cdot 5 = 1150$
D (25,0)	$60 \cdot 25 + 50 \cdot 0 = 1500$

It is clear from the table above that the value of the Objective Function is minimum at B (8, 12).

Thus the solution of the LPP is given as $Z_{min} = 1080$ miligrams and the corresponding values of the decision variables are $x = 8$ and $y = 12$

Hence Mr. Lal should take Type A meal for 8 days and Type B for 12 days to intake least cholesterol.

Q5

Dec '23

ZOXIN Ltd., a manufacturing company is planning to market a new model of a doll. Rather than setting the selling price of the doll based only on production cost estimation, management polls the retailers of the doll to see how many dolls they will buy for various prices. From this survey, it is determined that the unit demand function is $X = 1500 - 75p$, and the cost function is given by $C = 4x + 1400$, for the doll, where P is the price per unit and x is the number of units demanded.

Required:

- (i) **Evaluate** how many number of dolls are sold to the retailers to maximize the profit of the company.
- (ii) **Identify** the price the company should charge to tetailers in order to obtain maximum profit.

(iii) **Assess** the maximum profit available to ZOXIN Ltd.

[7]

Reference	What's New
Maximum Profit	

Answer

- (i) Dolls = 600
- (ii) Price = ₹ 12
- (iii) Profit (Maximum) = ₹ 3400

SJC Institute

Every student is different

SJC HAS METHODS TO TEACH EVERY TYPE OF STUDENT

ONLY CLASSES
For Top-performing students Who are disciplined, sincere, and confident.

CLASSES + MOCK TEST
For self-disciplined, sincere, students who seek reassurance for improvement.

ONE STOP PASS SYSTEM
For students who needs a push to study with continuous evaluation system but have taken classes haphazardly.

SURE SHOT BATCH
For students who start early & want to stay organized from day one.

SCAN HERE

Become Our ROCKET STUDENT

Register for full group of any level of CA-CMA-CS & get the following **BENEFITS** :

- 01** 1 to 1 Preparation Assessment worth Rs. 2499/-
- 02** 10% OFF on Next Group Combo
- 03** 10% OFF on Group Mock Test Sangram (MTS)
- 04** 10% OFF on One Stop Passing System (OSPs)
- 05** 5% MONEY BACK for every Referral you give us

SCAN HERE

CA/CMA INTERNSHIP WORKSHOP

What we will cover?

- Importance of Internship?
- How it will help you in real world?
- How to start?
- Which area is good for you?

SCAN HERE

CA Girish Ganeriwala
CA Satish Jalan

FINANCE PRACTICAL TRAINING BASIC COURSE

Journey from Learning to Understanding

Grow yourself in any sphere by gaining the Confidence over the Numbers

SCAN HERE

CA Girish Ganeriwala
CA Satish Jalan

Chapter 7

Transportation

Q1

June'23 MTP Set 1

Problems of Linear Programming with objective of minimizing Total Cost of transportation of a particular commodity from different Sources to various Destinations is solved using the methodology of Transportation technique. Traditionally such problems involve one Objective function. But in real life, problems involve more than one Objective function. An example of such type, is transportation of perishable items or deteriorating items. For these items minimization of deterioration is equally important along with that of cost of transportation.

Egg is a commodity which comes under the category of deterioration in the form of its breakage. Any broken egg is of zero value to the manufacturing firms. Thus minimization of breakage of eggs during transportation is one of the most important objectives of the egg transportation problem. At the same time there are the other important objectives too, like minimization of distance travelled to supply, optimization of time taken to supply etc. In fact, these factors are all related to the minimization of deterioration. As eggs are traditionally transported through roads in our country, which are not of best possible quality as far as smoothness is concerned, chances of breakage increase with increased distance travelled. Similarly, optimization of time taken to reach the Destination (which has a relationship with the speed of the transporting vehicle) is important because more the speed of the vehicle less is the time taken to reach but with a higher chance of breakage of eggs. So it is quite clear that logistics and supply chain for eggs is a multi-objective problem of transportation.

Help of software is needed to find solution of such problems without any hassle. In fact, the solutions obtained are heuristic type where some compromise among the optimum values of the individual functions is done to reach the ultimate goal.

A problem of transportation of eggs is given as follows –

Suppose there are three sources A, B & C with capacities (in lakhs of eggs) 8, 5 & 3 respectively to supply eggs to three destinations I, II & III having respective demands (in lakhs of eggs) of 5, 3 and 2. The distance in kilometres between the sources and destinations are given in the following matrix.

From Source To Destination

From Source	To Destination		
	I	II	III
A	551	314	280
B	521	267	341
C	396	142	193

Software provided the following optimal allocation of eggs to the different cells of the matrix while going for distance minimization: - A – III = 2, B – I = 2, B – II = 3 and C – I = 3

Based on the above, the minimum distance to be travelled is given to be 1464 Kms. which has the break-up of (280 + 521 + 267 + 396).

The objective of minimization of Percentage Breakage of eggs is taken care of based on the following data

From Source	To Destination @ 30 Kmph			To Destination @ 35 Kmph			To Destination @ 40 Kmph		
	I	II	III	I	II	III	I	II	III
A	5.00	2.85	2.54	5.50	3.13	2.80	6.00	3.42	3.05
B	4.77	2.42	3.10	5.20	2.66	3.40	5.67	2.91	3.71
C	3.61	1.29	1.75	3.95	1.42	1.93	4.13	1.55	2.00

Optimal allocations for different Speeds of vehicles as provided by the software are given in the tables below.

From Source	To Destination @ 30 Kmph			To Destination @ 35 Kmph			To Destination @ 40 Kmph			Supply in Lakhs
	I	II	III	I	II	III	I	II	III	
A			2		2				2	8
B	2	3		2	3		2	3		5
C	3			3			3			3
Demand in Lakhs	5	3	2	5	3	2	5	3	2	

Using the methodology similar to that of Distance minimization, the total breakage percentage for a speed of 30 Kmph is found to be 13.34 and the average breakage percentage is 3.335.

Total Transportation cost is found to be ₹ 2,80,000/-

Based on the above information answer the following questions –

1. Instead of using the software if the problem is to be solved manually then **formulate** the first step.
2. **Is** the figure of average breakage percentage correct for a speed of 30 Kmph? **Justify**.
3. **What** is the Transportation Cost of an egg per kilometre of distance travelled?
4. **Formulate** a matrix for minimizing the time taken to supply when the vehicle speed is 35 Kmph.

[8]

Reference

What's **New**
Balancing, Average Speed, Transportation Cost

Answer

- (1) As per the given information, Total demand of eggs = 10 Lakh pieces and Total supply is 16 Lakh pieces. Thus the problem is unbalanced one with Supply > Demand
- So, the very first step should be to make it balanced by introducing a DUMMY destination having a demand of $16 - 10 = 6$ Lakh pieces.
- (2) When the vehicle speed is 30 Kmph then the total percentage of broken eggs is $(2.54 + 4.77 + 2.42 + 3.61) = 13.34$.
- So, the average percentage of broken eggs = $13.34 \div 4 = 3.335$.
- Hence the figure of average breakage percentage for a speed of 30 Kmph is correct.
- (3) Total Cost of transportation = ₹ 280000/-, Total No. of eggs to be supplied = 1000000
- Minimum total distance to be travelled = 1464 Kms.
- So, Cost of Transportation per egg per Km = $280000 \div (1000000 \times 1464) = ₹ 0.00019$.
- (4) Time (Hours) Matrix for Vehicle Speed 35 kmph

From Source	To Destination		
	I	II	III
A	15.74	8.97	8.00
B	14.89	7.63	9.74
C	11.31	4.06	5.51

Note : Time in hours = Distance in Km \div Speed in Kmph.

Q2

June'23 MTP Set 2

A multi-plant company has three manufacturing plants, A, B and C. It sells products in two markets X and Y. Production cost at A, B and C is ₹ 1,500; 1,600; and 1,700 per piece respectively. Selling prices in X and Y are ₹ 4,400 and ₹ 4,700 respectively. Demands in X and Y are 3,500 and 3,600 piece respectively. Production capacities at A, B and C are 2,000; 3,000 and 4,000 pieces respectively. Transportation costs are as shown in the table below. Build a mathematical model.

Plant	Market	
	X	Y
A	1,000	1,500
B	2,000	3,000
C	1,500	2,500

[7]

Reference

Formulation of LP for Transportation

What's **New**

Answer

Here three plants differ in production cost. Therefore, our problem is to determine the schedule of production which may result in the maximum profit. The various profits per item are as shown in the adjacent table.

Plant	Market	
	X	Y
A	1,900	1,700
B	800	100
C	1,200	500

The profit (selling price - production cost - transportation cost) data from plants to markets are shown below:

from A to X: $4400 - 1500 - 1000 = 1900$;

from A to Y: $4700 - 1500 - 1500 = 1700$;

From B to X: $4400 - 1600 - 2000 = 800$; and so on.

Further, total production at A, B and C plants is $2,000 + 3,000 + 4,000 = 9,000$ units while total requirement at X and T is $3,500 + 3,600 = 7,100$ units. Hence this is an unbalanced transportation problem. By introducing a dummy market Z to receive an excess production of $9,000 - 7,100 = 1,900$ units, the complete relevant information is summarized in the following table:

Plant	Market			Supply
	X	Y	Dummy	
A	1900 x_{11}	1700 x_{12}	0 x_{13}	2000
B	800 x_{21}	100 x_{22}	0 x_{23}	3000
C	1200 x_{31}	500 x_{32}	0 x_{33}	4000
Demand	3500	3600	1900	9000

Let x_{ij} be quantity to be transported from plant i , ($i = 1, 2, 3$) to market j , ($j = 1, 2, 3$). Now the LP model based on the given data can be formulated as follows:

$$\text{Maximize (total profit) } Z = 1900x_{11} + 1700x_{12} + 800x_{21} + 100x_{22} + 1200x_{31} + 500x_{32}$$

Subject to the constraints

$$x_{11} + x_{12} + x_{13} = 2,000$$

$$x_{21} + x_{22} + x_{23} = 3,000$$

$$x_{31} + x_{32} + x_{33} = 4,000$$

$$x_{11} + x_{21} + x_{31} = 3,500$$

$$x_{12} + x_{22} + x_{32} = 7,600$$

$$x_{13} + x_{23} + x_{33} = 1,900$$

$$x_{ij} \geq 0 \text{ for all } i \text{ and } j$$

supply constraints

demand constraints

SJC Institute

Become Our **ROCKET STUDENT**

Register for **full group** of any level of **CA-CMA-CS** & get the following **BENEFITS**:

01

1 to 1 Preparation Assessment worth **Rs. 2499/-**

02

10% OFF on Next Group Combo

03

10% OFF on Group Mock Test Sangram (MTS)

04

10% OFF on One Stop Passing System (OSPS)

05

5% MONEY BACK for every Referral you give us

- You may choose from **any faculties** on SJC Website
- If you have registered only one subject, then you may register other subjects of the same group **within 15 days** to claim these benefits

Please connect with us at **8100 11 2222** with your registration details to know more



Chapter 8
Assignment

Q1

June'23 MTP Set 1

Consider a problem of assigning four officers to four tasks. The time (hours) required to complete the tasks is given below:

Officer	Tasks			
	A	B	C	D
Officer 1	4	7	5	6
Officer 2	-	8	7	4
Officer 3	3	-	5	3
Officer 4	6	6	4	2

Officer 2 cannot be assigned to task A and officer 3 cannot be assigned to task B.

Find all the optimal assignment schedules.

[8]

<p>Reference Optimal Assignment</p>	<p>What's New Prohibited Cells</p>
---	--

Answer

Step 1: Assign a high cost, denoted by M, to the pair (A, 2) and (B, 3).

ROW SUBTRACTION

Officer \ Task	A	B	C	D
1	0	3	1	2
2	M	4	3	0
3	0	M	2	0
4	4	4	2	0

COLUMN SUBTRACTION

Officer \ Task	A	B	C	D
1	0	0	0	2
2	M	1	2	0
3	0	M	1	0
4	4	1	1	0

Step 2 : Draw minimum number of straight lines to cover all zeros.

Officer \ Task	A	B	C	D
1	0	0	0	2
2	M	1	2	0
3	0	M	1	0
4	4	1	1	0

Step 3 : Smallest uncovered number subtracted from uncovered numbers, added to numbers at intersection of two lines.

Officer \ Task	A	B	C	D
1	1	0	0	3
2	M	0	1	0
3	0	M	0	0
4	4	0	0	0

Step 4 : Return to step 2. Cover all zeros. Since the number of lines is 4, the optimum solution is reached

Officer \ Task	A	B	C	D
1	1	0	⊗	3
2	M	⊗	1	0
3	0	M	⊗	⊗
4	4	⊗	0	⊗

Assign:

Officer		Job	Time
1	to	B	7 hrs
2	to	D	4 hrs
3	to	A	3 hrs
4	to	C	4 hrs
		Total	18 hrs

Q2

Postal Test Paper

A travelling salesman has to visit five cities. He wishes to start from a particular city, visit each city once and then return to his starting point. The travelling cost (in ₹ 00) between any two cities is given in the table below:

From city	To City				
	A	B	B	D	E
A	M	5	8	4	5
B	5	M	7	4	5
C	8	7	M	8	6
D	4	4	8	M	8
E	5	5	6	8	M

Find the cost minimising sequence of visit. [7]

Reference

Travelling Salesman

What's New

Answer

Table – 1 showing reduced matrix after Row subtraction operation

From City	To City				
	A	B	C	D	E
A	M	1	4	0	1
B	1	M	3	0	1
C	2	1	M	2	0
D	0	0	4	M	4
E	0	0	1	3	M

Table – 2 showing reduced matrix after Column subtraction operation

From City	To City				
	A	B	C	D	E
A	M	1	3	0	1
B	1	M	2	0	1
C	2	1	M	2	0
D	0	0	3	M	4
E	0	0	0	3	M

Here minimum number of horizontal and vertical straight lines to cover all the zeros = 4 \neq Order (5) of the matrix. So the solution is non-optimal. Improvement of the above matrix is done by subtracting the minimum value of the uncovered elements i.e. 1 from all the uncovered elements and adding the same to the elements at the junction of the horizontal and vertical lines. The resultant matrix is shown below.

Table – 3 showing improved matrix (Optimal)

From City	To City				
	A	B	C	D	E
A	M	0	2	0	1
B	0	M	1	0	1
C	1	0	M	2	0
D	0	0	3	M	5
E	0	0	0	4	M

Here the minimum number of straight lines required to cover all the zeros = 5 = Order of the matrix. So the solution is optimal. Now assignments are done by following the standard rules of Hungarian Method as below.

Table – 4 showing matrix with Optimal Assignments (Alternative – 1)

From City	To City				
	A	B	C	D	E
A	M	0	2	3	1
B	1	M	1	0	1
C	1	0	M	2	0
D	0	0	3	M	5
E	0	0	0	4	M

As per the solution above, the Salesman will travel from A to B, then B to D, then D to A. But this is not meeting the requirement of travelling through all the cities and finally returning to the starting point i.e.. A. Hence the solution is unacceptable.

Table – 5 showing matrix with Optimal Assignments (Alternative – 2)

From City	To City				
	A	B	C	D	E
A	M	0	2	0	1
B	0	M	1	0	1
C	1	0	M	2	0
D	0	0	3	M	5
E	0	0	0	4	M

Again the solution above shows the travelling route as A to D, then D to B, then B to A. This is also not acceptable because of violation of the basic requirement of the problem.

Under the circumstances it is decided to try for the assignment at the cells which are having next highest entry after zero. It can be mentioned that as far as practicable Assignments should be done at the cells having 0 entry. Here next highest entry in the table after 0 is 1 and it appears at the four cells – (A, E), (B, C), (B, E) and (C, A). By arbitrarily choosing any one of these, assignment is done afresh. Let the cell (A, E) be chosen for the purpose

Table – 5 showing matrix with the required solution

From City	To City				
	A	B	C	D	E
A	M	0	2	0	1
B	0	M	1	0	1
C	1	0	M	2	0
D	0	0	3	M	5
E	0	0	0	4	M

Using the standard procedure of Hungarian Method assignments are made starting from 1st Row cell (A, E) and finally required solution is reached which shows the travel route of the salesman as – A to E, E to C, C to B, B to D and D to A. Minimum Cost of travel is $5 + 4 + 7 + 4 + 6 = 26$



June'23

A travelling salesman has to visit five cities. S,T, X,Y and Z. The inter city distances are tabulated below. Note the distance between two cities not be same both ways.

From /To	S	T	X	Y	Z
S	-	14	26	27	17
T	8	-	18	20	9
X	12	13	-	20	14
Y	16	19	24	-	18
Z	14	15	25	27	-

The distance are in km.

Required:

If the travelling salesman starts from City S and has to come back to city S, by applying the principle of quantitative technique, **which** route would you advise him to take so that total distance travelled by him is minimized? [8]



Reference

Travelling SalesmanWhat's **New****Answer****(i) Row Minimisation**

-	0	12	13	3
0	-	10	12	1
0	1	-	8	2
0	3	8	-	2
0	1	11	2	-

(ii) Column Minimisation

-	0	4	11	2
0	-	2	10	0
0	1	-	6	1
0	3	0	-	1
0	1	3	0	-



(iii) Boxing

	S	T	X	Y	Z
S	-	0	4	11	2
T	X	-	2	10	0
X	0	1	-	6	1
Y	X	3	0	-	1
Z	X	1	3	0	-

Cycle

S → T → Z → Y → X

Optimum Assignment

From	To	Cost
S	T	14
T	Z	9
X	S	12
Y	X	24
Z	Y	27
		86

Q4

Dec '23

Mr. Tushar, production supervisor is considering how he should assign five jobs that are to be performed, to the mechanists working under him. He wants to assign the jobs to the mechanists in such a manner that the aggregate cost to perform the jobs is the least. He has following information about the wages paid to the mechanists for performing these jobs.

Mechanists	Jobs				
	1	2	3	4	5
A	10	3	3	2	8
B	9	7	8	2	7
C	7	5	6	2	4
D	3	5	8	2	4
E	9	10	9	6	10

Required :

Analyse and assign the jobs to the mechanists so that the aggregate cost is the least. [7]

Reference

Minimization ProblemWhat's **New****Answer**

The given problem is a standard minimization problem.

Subtracting minimum element of each row from all the elements of that row, the given problem reduces to

		JOBS				
Mechanist	1	2	3	4	5	
A	8	1	1	0	6	
B	7	15	6	0	5	
C	5	3	4	0	2	
D	1	3	6	0	2	
E	3	14	3	0	4	

Subtract the minimum element of each column from all the elements of that column. Draw the minimum number of lines horizontal or vertical so as to cover all zeros.

		JOBS				
Mechanist	1	2	3	4	5	
A	7	0	0	0	4	
B	6	4	5	0	0	
C	4	2	3	0	0	
D	0	2	5	0	0	
E	2	3	2	0	2	

Since the minimum number of lines covering all zeros is equal to 4 which is less than the number of columns/ row (=5), the above table will not provide optimal solution. Subtract the minimum uncovered element (=2) from all uncovered elements and add to the elements lying on the intersection of two lines, we get the following matrix.

		JOBS				
Mechanist	1	2	3	4	5	
A	7	0	0	2	6	
B	4	2	3	0	3	
C	2	0	1	0	0	
D	0	2	5	2	2	
E	0	1	0	0	2	

Since the minimum number of horizontal and vertical lines to cover all zeros is equal to five which is equal to the order of the matrix, the above table will give the optimal solution. The optimal assignment is made below.

JOBS					
Mechanist	1	2	3	4	5
A	7	0	3	2	6
B	4	2	3	0	3
C	2	3	1	2	0
D	0	2	5	2	2
E	3	1	0	2	2

The optimal assignment is given below:

Mechanist	Job	Wages (₹)
A	2	3
B	4	2
C	5	4
D	1	3
E	3	9
		21

The total least cost associated with the optimal mechanist-job assignment =21

One-Stop Pass System

For students who needs a push to study with continuous evaluation system but have taken classes haphazardly

SCAN HERE



Sure Shot Batch

आप बस पढाई कीजिए
पूरी PLANNING हमारी

SCAN HERE



BOUNCE BACK ASSESSMENT

To Bounce Back you need to do something different. But what? Take our Bounceback Assessment to know.

SCAN HERE



PREPARATION ASSESSMENT

Know whether you are
on the right track

SCAN HERE



Mock test Sangram

The more you sweat in practice, the less you bleed in Battle

SCAN HERE



Rankers Batch

Are you aiming for a
top rank in exams?
Join our Rankers Batch

SCAN HERE



Chapter 9

Game Theory

Q1

June'23 MTP Set 1

Infer the optimum solution of the Game using Dominance Principle

$$\begin{bmatrix} 15 & 2 & 3 \\ 6 & 5 & 7 \\ -7 & 4 & 0 \end{bmatrix}$$

[8]

Reference

What's New

Dominance Principle

Answer

Let the given Game is played by the players A and B with A (the maximizing player) having strategies A₁, A₂ and A₃, represented along the rows and B (the minimizing player) having strategies B₁, B₂ and B₃ represented along the columns. So the given payoff Matrix can be written as follows –

Strategies of A	Strategies of B		
	B ₁	B ₂	B ₃
A ₁	15	2	3
A ₂	6	5	7
A ₃	-7	4	0

All the elements of Row A₃ are less than the corresponding elements of Row A₂. So A₃ is dominated by A₂. Hence it is ignored and deleted. The new matrix is given below.

Strategies of A	Strategies of B		
	B ₁	B ₂	B ₃
A ₁	15	2	3
A ₂	6	5	7

Here all the elements of B3 are more than the corresponding elements of B2. Hence B3 is dominated by B2 and ignored to get the new matrix below.

Strategies of A	Strategies of B		
	B ₁	B ₂	Row Min.
A ₁	15	2	2
A ₂	6	5	5
Column Max.	15	5	

Maximum among the Row minimums = 5 = Maximin value and Minimum among the Column maximums = 5 = Minimax value. As, Maximin and Minimax values are equal, there exists a Saddle Point. It occurs at the cell A₂B₂.

Hence optimal strategies of A and B are respectively A₂ and B₂. Also value of the Game = 5

Q2

June'23

A and B play game in which each has three coins, a 5R, 10R and 20R. Each selects a coin without the knowledge of the other's choice. If the sum of the coins is an odd amount, A wins B's coin, if the sum is even B wins A's coin.

Required:

- (i) **Prepare** the pay-off matrix for two players (A and B).
- (ii) **Find** the best strategy for each player and
- (iii) **Calculate** the value of Game using Dominance Principle. [8]



Reference
Pay-off Matrix, Best Strategy, Dominance Principle

What's New

Answer

Payoff (Net gain)

A (Maximising)

		B		
		5	10	20
A	5	B (Net Gain 5)	A(10)	A(20)
	10	A(5)	B(10)	B(10)
	20	A(5)	B(20)	B(20)

Best strategy A = 5 [2 times win chance]

B = 10 or 20 but 10 is preferred to minimise loss

Value of Game

Comparing R₂ and R₃

Dominance

R₂ can be eliminated (Lower)

		B		
		C ₁	C ₂	C ₃
A	R ₁	5	10	20
	R ₃	5	20	20

Comparing C₁ and C₃

C₃ can be eliminated

		B		
		C ₁	C ₂	C ₃
A	R ₁	5	10	5
	R ₃	5	20	5

Minimax 5 20

∴ Value of Game = 0

Q3

Postal Test Paper

The Management of a company is negotiating with its Union for revision of hourly wages of its employees. The Management deployed a Consulting Firm who has prepared a payoff matrix for the purpose which indicates the additional hourly cost (in ₹) to the company. It is shown below: you being a part of the Consulting Firm have to assist the Management in selecting the best strategy.

Management's Strategies	Strategies of the Union			
	U1	U2	U3	U4
M1	2.50	2.70	3.50	-0.20
M2	2.00	1.60	0.80	0.80
M3	1.40	1.20	1.50	1.30
M4	3.00	1.40	1.90	0

What is the value of the game? **How** is it going to affect the company's cost?

[7]

Reference

Mixed Strategy - Odds Method

What's **New**

Rule of Dominance

Answer

As the Management's objective is to minimise the cost, they can be considered as the Minimising Player and the Union as the Maximising Player in this problem of Game. Thus, to solve the problem we have to recast the given Payoff Matrix by transposing it as below:-

Strategies of the Union	Management's Strategies				Row Minimum
	M ₁	M ₂	M ₃	M ₄	
U ₁	2.50	2.00	1.40	3.00	1.40 = Maximin
U ₂	2.70	1.60	1.20	1.40	1.20
U ₃	3.50	0.80	1.50	1.90	0.80
U ₄	-0.20	0.80	1.30	0	-0.20
Column Maximum	3.50	2.00	1.50 = Minimax	3.00	

Maximin value (1.40) ≠ Minimax value (1.50). Thus, Saddle Point does not exist. So this is a problem of Mixed Strategy. Since the matrix is not a (2 × 2) Matrix, Dominance Rules are applied to reduce its size to make it a (2 × 2) Matrix.

As all the elements of the 3rd Row of the above matrix are either greater than or equal to the corresponding elements of the 4th Row, the 3rd Row can be considered to dominate the 4th.

So the 4th Row is ignored and the new matrix is shown below.

Strategies of the Union	Management's Strategies		
	M ₂	M ₃	M ₄
U ₁	2.00	1.40	3.00
U ₂	1.60	1.20	1.40
U ₃	0.80	1.50	1.90

Again all the elements of the 1st Column are greater than the corresponding elements of the 2nd Column, the 1st Column is dominated by the 2nd Column. So the 1st Column is ignored and the new matrix is shown below.

Strategies of the Union	Management's Strategies		
	M ₂	M ₃	M ₄
U ₁	2.00	1.40	3.00
U ₂	1.60	1.20	1.40
U ₃	0.80	1.50	1.90

All the elements of the 3rd Column (i.e. for Strategy M4) of this matrix are more than the corresponding elements of 2nd Column (i.e. for Strategy M3). Hence M4 is dominated by M3 and ignored. The new matrix is shown below.

Strategies of the Union	Management's Strategies	
	M ₂	M ₃
U ₁	2.00	1.40
U ₃	0.80	1.50

This is a (2 × 2) Matrix. Now the problem of Game is solved by using Odds Method. Odds are calculated as below.

Strategies of the Union	Management's Strategies		ODDs
	M ₂	M ₃	
U ₁	2.00 = a ₁	1.40 = a ₂	b ₁ - b ₂ = 0.80 - 1.50 = 0.70
U ₃	0.80 = b ₁	1.50 = b ₂	a ₁ - a ₂ = 2.00 - 1.40 = 0.60
ODDs	a ₂ - b ₂ = 1.40 - 1.50 = 0.10	a ₁ - b ₁ = 2.00 - 0.80 = 1.20	Sum of the ODDs = 1.30

Probabilities of the Union and the Management taking their different strategies are calculated as follows – $P(U_1) = (b_1 - b_2) \div [(b_1 - b_2) + (a_1 - a_2)] = 0.70 / [0.70 + 0.60] = 0.70/1.30 = 7/13$

$$P(U_3) = (a_1 - a_2) \div [(b_1 - b_2) + (a_1 - a_2)] = 0.60 / [0.70 + 0.60] = 0.60/1.30 = 6/13$$

$$P(M_2) = (a_2 - b_2) \div [(a_2 - b_2) + (a_1 - b_1)] = 0.10 / [0.10 + 1.20] = 0.10/1.30 = 1/13$$

$$P(M_3) = (a_1 - b_1) \div [(a_2 - b_2) + (a_1 - b_1)] = 1.20 / [0.10 + 1.20] = 1.20/1.30 = 12/13$$

$$\text{Value of the Game} = v = [a_1(b_1 - b_2) + b_1(a_1 - a_2)] \div [(b_1 - b_2) + (a_1 - a_2)] = [2.00 \times 0.70 + 0.80 \times 0.60] \div [0.70 + 0.60]$$

$$= [1.40 + 0.48] / 1.30 = 1.88/1.30 = 1.45$$

So the Union chooses its Strategies U₁, U₂, U₃ & U₄ with probabilities (7/13, 0, 6/13, 0) and the Management chooses its Strategies M₁, M₂, M₃ & M₄ with probabilities (0, 1/13, 12/13, 0).

Expected Gain to the Union is ₹ 1.45 and the corresponding Loss to the Management is ₹ 1.45.

Thus, the hourly cost of the company will increase by ₹ 1.45

Q4

MTP Dec'23 Set 1

Solve the Game using Dominance Principle

$$\begin{bmatrix} 15 & 2 & 3 \\ 6 & 5 & 7 \\ -7 & 4 & 0 \end{bmatrix}$$

<p>Reference</p> <p>Pure Strategy</p>	<p>What's New</p> <p>Rule of Dominance</p>
---	--

Answer

Let the given Game is played by the Players A and B with A (the maximising player) having strategies A_1, A_2 and A_3 represented along the rows and B (the minimising player) having strategies B_1, B_2 and B_3 represented along the columns. So the given Payoff Matrix can be written as follows –

Strategies of A	Strategies of B		
	B_1	B_2	B_3
A_1	15	2	3
A_2	6	5	7
A_3	-7	4	0

All the elements of Row A_3 are less than the corresponding elements of Row A_2 . So A_3 is dominated by A_2 . Hence it is ignored and deleted. The new matrix is given below.

Strategies of A	Strategies of B		
	B_1	B_2	B_3
A_1	15	2	3
A_2	6	5	7

Here all the elements of B_3 are more than the corresponding elements of B_2 . Hence B_3 is dominated by B_2 and ignored to get the new matrix below.

Strategies of A	Strategies of B		Row Min
	B_1	B_2	
A_1	15	2	2
A_2	6	5	5
Column Max.	15	5	

Maximum among the Row minimums = 5 = Maximin value and Minimum among the Column maximums = 5 = Minimax value. As, Maximin and Minimax values are equal, there exists a Saddle Point. It occurs at the cell $A_2 B_2$.

Hence optimal strategies of A and B are respectively A_2 and B_2 . Also value of the Game = 5

[NOTE – This is a problem of Pure Strategy and could have been solved without the use of Dominance Rules, but the question has specifically asked for the usage of Dominance Rules. So the same is used.]

SJC Institute

Every student is different

SJC HAS METHODS TO TEACH EVERY TYPE OF STUDENT

For Top-performing students Who are disciplined, sincere, and confident.

ONLY CLASSES

For self-disciplined, sincere, students who seek reassurance for improvement.

CLASSES + MOCK TEST

For students who needs a push to study with continuous evaluation system but have taken classes haphazardly

ONE STOP PASS SYSTEM

For students who start early & want to stay organized from day one

SURE SHOT BATCH

SCAN HERE

Become Our ROCKET STUDENT

Register for full group of any level of CA-CMA-CS & get the following **BENEFITS**:

- 01** 1 to 1 Preparation Assessment worth Rs. 2499/-
- 02** 10% OFF on Next Group Combo
- 03** 10% OFF on Group Mock Test Sangram (MTS)
- 04** 10% OFF on One Stop Passing System (OSPs)
- 05** 5% MONEY BACK for every Referral you give us

SCAN HERE

CA/CMA INTERNSHIP WORKSHOP

What we will cover?

- Importance of Internship?
- How it will help you in real world?
- How to start?
- Which area is good for you?

SCAN HERE

CA Girish Ganeriwala
CA Satish Jalan

FINANCE PRACTICAL TRAINING BASIC COURSE

Journey from Learning to Understanding

Grow yourself in any sphere by gaining the Confidence over the Numbers

SCAN HERE

CA Girish Ganeriwala
CA Satish Jalan

Chapter 10 Simulation

Q1

June'23 MTP Set 2

At a service station a study was made over a period of 50 days to determine both the number of automobiles being brought in for service and the number of automobiles serviced. The results are given in the adjoining table:

No. of automobiles arriving for service or completing services/day	Frequency of arrival	Frequency of daily serviced
0	4	6
1	8	4
2	20	24
3	10	6
4	6	8
5	2	2

Simulate the arrival service pattern for a ten-day period and estimate the mean number of automobiles that remain in service for more than a day.

Use the following series of random numbers:

For arrivals	09	54	42	01	80	06	06	26	57	79
For Service	49	16	36	76	68	91	97	85	56	84

[8]

Reference

Mean Number of Automobiles

What's New

Answer

The cumulative probability distributions and random number intervals both for inter arrival time and service time are shown in table below:

Determination of Random Number Internal

No. of arrivals / services / day	Arriving pattern			Servicing pattern				
	Frequency	Probability	Cum. Prob	RN Internal	Frequency	Probability	Cum. Prob	RN Internal
0	4	4/50	0.08	00-07	6	6/50	0.12	00-11
1	8	8/50	0.24	08-23	4	4/50	0.20	12-19
2	20	20/50	0.64	24-63	24	24/50	0.68	20-67
3	10	10/50	0.84	64-83	6	12/50	0.80	68-79
4	6	6/50	0.86	84-95	8	8/50	0.96	80-95
5	2	2/50	1.00	96-99	2	2/50	1.00	96-99

The simulation worksheet developed to the problem is shown in table below: Simulation Experiments Worksheet

Day	Arrivals		Services		Total no. held from previous day	Total waiting for services	Number services	Held for Next Day
	Random number	Simulated arrival	Random number	Simulated services				
1	09	01	49	02	00	01	02	-
2	54	02	16	01	00	02	01	01
3	42	02	36	02	01	03	02	01
4	01	00	76	03	01	01	03	-
5	80	03	68	03	00	03	03	-
6	06	00	91	04	00	00	04	00
7	06	00	97	05	00	00	05	00
8	26	02	85	04	00	02	04	-
9	57	03	56	02	00	03	02	01
10	79	03	84	04	04	04	04	-

Average number of automobiles remaining in service for more than one day = 3/10

Q2

MTP Dec'23 Set 1

Patients arriving at a village dispensary are treated by a doctor on a first-come-first-served basis. The inter-arrival time of the patients is known to be uniformly distributed between 0 and 80 minutes, while their service time is known to be uniformly distributed between 15 and 40 minutes. It is desired to simulate the system and determine the average time a patient has to be in the queue for getting service and the proportion of time the doctor would be idle.

Carry out the simulation using the following sequences of random numbers. The numbers have been selected between 00 and 80 to estimate inter-arrival times and between 15 and 40 to estimate the service times required by the patients.

Series 1	07	21	12	80	08	03	32	65	43	74
Series 2	23	37	16	28	30	18	25	34	19	21

<p>Reference</p> <p>Waiting Line Simulation</p>	<p>What's New</p> <ul style="list-style-type: none"> • No Random Interval • Average waiting time of Patient and Doctor
---	---

Answer

Simulation of data at a village dispensary

No. of patients	Inter arrival time Random No. (minutes)	Entry time in to queue (hrs)	Service Time Random No. (minutes)	Service Start time (hrs)	End time (hrs)	Waiting time of patient (minutes)	Idle time of doctor (minutes)
1	07	8.07	23	8.07	8.30	-	07
2	21	8.28	37	8.30	9.07	2	-
3	12	8.40	16	9.07	9.23	27	-
4	80	10.00	28	10.00	10.28	-	37
5	08	10.08	30	10.28	10.58	20	-
6	03	10.11	18	10.58	11.16	47	-
7	32	10.43	25	11.16	11.41	33	-
8	65	11.48	34	11.48	12.22	-	07
9	43	12.31	19	12.31	12.50	-	09
10	74	01.45	21	01.45	02.06	-	55
Total (in minutes)						129	115

Average waiting time of patient = $129 / 10 = 12.9$ minutes

Average waiting time of doctor = $115 / 10 = 11.5$ minutes

It has been assumed that starting time be 8.00 A.M.

Q3

Postal Test Paper

The past data of demand per week (in '00 kgs.) of a confectionery item is given below –

Demand/Week	0	5	10	15	20	25
Frequency	2	11	8	21	5	3

Using the sequence of random numbers – 35, 52, 13, 90, 23, 73, 34, 57, 35, 83, 94, 56, 67, 66

generate the demand for the next 10 weeks. Also find out the average demand per week.

Reference	What's New
Average Demand per week	

Answer

Table showing Random Number Range for Demand

Demand/ week	Frequency (f)	Probability ($p = f / \Sigma f$)	Cumulative Probability	Range
0	2	.04	.04	00-03
5	11	.22	.26	04-25
10	8	.16	.42	26-41
15	21	.42	.84	42-83
20	5	.10	.94	84-93
25	3	.06	1.00	94-99
Total	$\Sigma f = 50$	1.00		

Table showing Simulated values for the next ten weeks

Week	Random No.	Demand in '00 Kgs.
1	35	10
2	52	15
3	13	5
4	90	20
5	23	5
6	73	15
7	34	10
8	57	15
9	35	10
10	83	15
		Total = 120

Explanatory Note on the method of obtaining simulated demand :

35 is the first one of the given Random Nos. So it is used for Week 1. Also 35 lies within the Range 26-41 of the previous table. Again 10 is the demand / week for the range 26-41. Hence demand for week 1 is 10. Similarly, the demands for the other weeks are simulated.

Average demand per week = Total demand / No. of weeks = $120/10 = 12$ ('00) Kgs.

Q4

Dec '23

Sugam Travelling Agency has to deal with a number of clients. The time taken by the officer of the agency to deal with clients and the arrival pattern of clients follow the distribution given below:

Time to deal with the clients:

Minutes	Probability
2	0.05
4	0.10
6	0.15
10	0.30
14	0.25
20	0.10
30	0.05

Time elapsing between arrivals of clients:

Minutes	Probability
1	0.20
8	0.40
15	0.30
25	0.10

Required:

- (i) **Simulate** (he atrival and serving of 10 clients by taking the following Random numbers. Random Numbers for:

Arrival patten	02	48	43	75	89	36	96	-	47	36	61
Serving pattern	60	73	61	35	28	16	80	46	60	11	

- (i) **Indicate** which of the clients will wait for how many minutes.
- (iii) **Assess** probability of time office being idle, Laking the starting ime as 10am. [7]

<p>Reference</p> <p>Probability of the time office</p>	<p>What's New</p>
--	--------------------------

Answer

(i/ i/ iii)

Simulation Worksheet: (Starting Time at 10 AM)

Client No.	Random Nos. for arrival	Time between arrivals	Arrival time at (hrs)	Service beginning (hours)	Random Nos. for services (minutes)	Service time (minutes)	Service end (hours)	Time client waiting (minutes)	Time office idle (minutes)
1.	2	1	10.01	10.01	60	14	10.15	-	1
2.	48	8	10.09	10.15	73	14	10.29	6	—
3.	43	8	10.17	10.29	61	14	10.43	12	—
4.	75	15	10.32	10.43	35	10	10.53	11	—
5.	89	15	10.47	10.53	28	6	10.59	6	—
6.	36	8	10.55	10.59	16	6	11.05	4	—
7.	96	25	11.20	11.20	80	14	11.34	—	15
8.	47	8	11.28	11.34	46	10	11.44	6	—
9.	36	8	11.36	11.44	60	14	11.58	8	—
10.	61	15	11.51	11.58	11	4	12.02	7	—
								60	16

From the table above, it may be seen that the simulation study has been carried out on the queue system for duration of 122 minutes (10 AM to 12.02 PM). During this time, TIME OFFICE of the agency was idle for a total for 16 minutes.

Probability of the time office being idle 13.11%

Become Our **ROCKET STUDENT**

Register for **full group** of any level of **CA-CMA-CS** & get the following **BENEFITS**:

01

1 to 1 Preparation Assessment worth **Rs. 2499/-**

02

10% OFF on Next Group Combo

03

10% OFF on Group Mock Test Sangram (MTS)

04

10% OFF on One Stop Passing System (OSPS)

05

5% MONEY BACK for every Referral you give us

- You may choose from **any faculties** on SJC Website
- If you have registered only one subject, then you may register other subjects of the same group **within 15 days** to claim these benefits

Please connect with us at **8100 11 2222** with your registration details to know more



Network Analysis – PERT, CPM

Q1

June'23

DHAMIN & CO., an Audit firm having numerous clients with identical financial years, is faced with a problem of framing the audit programme in such a way that reports of all its clients do not get delayed. Manpower and time are its chief constraints. Mr. Panth, partner of the firm, an auditor, is a Manager in the same that he has to plan his audit programme, organize the firm's articles and its clerks, direct them to achieve their pre-determined objectives, control quality of work, time and cost, and lastly report his observations to the firm's clients. Thus, the knowledge of sophisticated techniques PERT/CPM helps him as an auditor to plan his audit programme logically and control avoidable and unnecessary delays and costs. In order to simplify the analysis, the following assumptions are made:

- (i) The audit is a medium sized limited company.
- (ii) A final or complete audit is undertaken.
- (iii) The size of the audit team is one senior and three juniors.
- (iv) No significant fraud or irregularities are observed to hamper the audit time schedule.
- (v) All queries are clarified during the process of audit itself.
- (vi) Expected time (duration) is based on past experience.

Activity and identification		Activity description	Preceded by	Expected Time (Days)		
				Optimistic	Most likely	Pessimistic
A	1-2	Persue the memorandum and Article of Association, prospectus etc. of the company	-	1	1	7
B	1-3	Scrutinize the Board Minutes and Important resolutions which have a bearing on accounts	-	1	4	7

C	1-4	Vouch and post cash book involving receipts and payments etc.	-	2	2	8
D	2-5	Test the efficiency of internal control in operation	A	1	1	1
E	3-5	Vouch and post purchases and sales ledger and check purchases and sales ledger balances	B	2	5	14
F	4-6	Examine journal entries and check their posting and examine and check trial balance	C	2	5	8
G	5-6	Verify and value various assets and liabilities of the company and check all the schedules forming part of P&L A/c and Balance Sheet	D & E	3	6	15
H	6-7	Ensure the truth and fairness of P&L A/c and Balance Sheet and finalise report keeping in mind the requirements of Sec. 143 of the Companies Act and forward it for approval and signature	F & G	1	2	3

Required:

- (i) **Design** the PERT network.
- (ii) **Identify** the critical path and assess the expected project (Audit) completion time.
- (iii) **Evaluate** what duration will have 95% confidence for project (Audit) completion.
- (iv) If the average duration for activity F increases to 14 days (assume its variance = 1), assess

what will be its effect on the expected project (Audit) completion time which will have 95% confidence.

Given:

Z Value	1.00	1.50	1.645	2.00
Probability	0.8413	0.9332	0.950	0.9772

<p>Reference</p> <p>PERT Network, Critical Path, Duration</p>	<p>What's New</p>
---	--------------------------

Answer

Part (I)

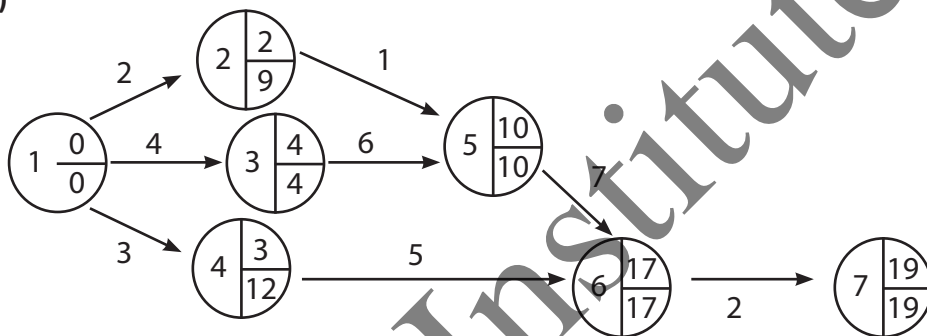

Part (II) CP = 1-3-5-6-7

Expected Duration = 19

Part (III) A ($Z < 1.645$)

$$Z = \frac{x - 19}{3.02}$$

$$1.645 = \frac{x - 19}{3.02}$$

$$x = 23.97 = 24 \text{ days}$$

Part (IV)

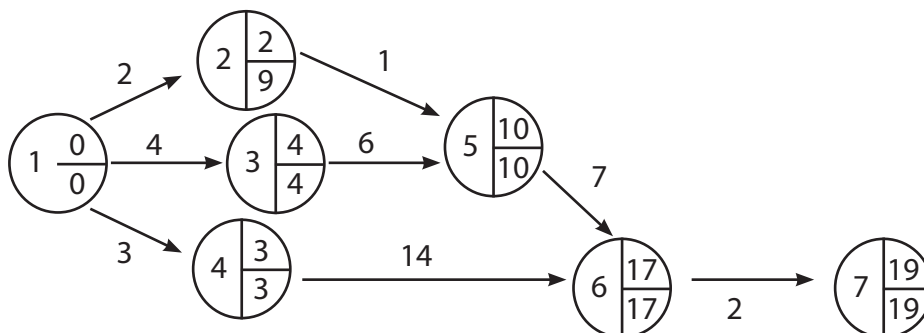

New CP = 1-4-6-7

Duration = 19

Variation = 1 + 1 + 0.11 = 2.11 (of new CP)

SD = 1.452

Z = 1.645 (Pb = 95%)

$$\frac{x - 19}{1.452} = 1.645 \quad x = 21.39 \text{ days} = 22 \text{ days (reduced by 2 days)}$$

Q2

Postal Test Paper

Distinguish between PERT and CPM.

 <p>Reference PERT & CPM</p>	<p>What's New</p>
--	--------------------------

Answer

Distinguish between PERT and CPM:

PERT	CPM
1. It is a technique for planning scheduling & controlling of projects whose activities are subject to uncertainty in the performance time. Hence it is a probabilistic model.	1. It is a technique for planning scheduling & controlling of projects whose activities not subjected to any uncertainty and the performance times are fixed. Hence it is a deterministic model.
2. It is an Event oriented system	2. It is an Activity oriented system
3. Basically does not differentiate critical and non- critical activities.	3. Differentiates clearly the critical activities from the other activities.
4. Used in projects where resources (men, materials, money) are always available when required.	4. Used in projects where overall costs is of primarily important. Therefore better utilized resources.
5. Suitable for Research and Development projects where times cannot be predicted.	5. Suitable for civil constructions.

Q3

MTP Dec'23 Set 1

The following table gives the activities and other relevant information related to “Making of a loaf”.

Activity	Preceded by	Elapsed Time (Minutes)			
A - Weigh ingredients	-	1			
B - Mix ingredients	A	3			
C - Dough rising time	B	60			
D - Prepare tins	-	1			
E - Pre-heat oven	-	10			
F - Knock back dough and place in tins	C&D	2			
G - 2nd dough rising time	F	15	H - Cooking time	E&G	45
H - Cooking time	E&G	45			

Draw a Network diagram. Also **find** the Earliest and Latest Times of each Event of the Network. **Identify** the different paths of the Network and their corresponding durations. **Which** path is critical? **Find** the time required to complete the job. [7]

<p>Reference</p> <p>Network diagram, Critical Path, Earliest Time, Latest Time, Duration of Project</p>	<p>What's New</p>
---	--------------------------

Answer

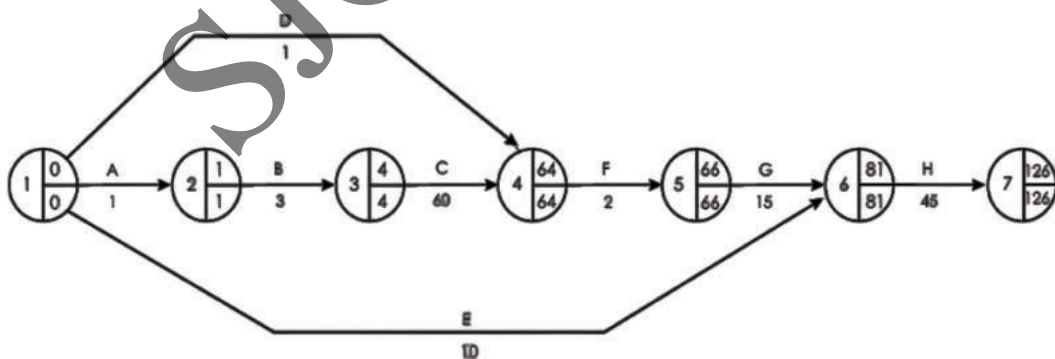

Q4

MTP June'23 Set 2

The following table gives data on normal time & cost. You need to develop the Network diagram and briefly discuss with reason the Critical Path.

Also find out the Normal duration of the project and analyse the corresponding Total Cost associated with it.

Activity	Normal	
	Time (days)	Cost (₹)
1 – 2	6	600
1 – 3	4	600
2 – 4	5	500
2 – 5	3	450
3 – 4	6	900
4 – 6	8	800
5 – 6	4	400
6 – 7	3	450

[6]

<p>Reference Network Diagram, Critical Path, Duration, Total Cost</p>	<p>What's New</p>
--	--------------------------

Answer

The network for normal activity times indicates project duration of 22 days with critical path 1-2-4-6-7. It is shown below.

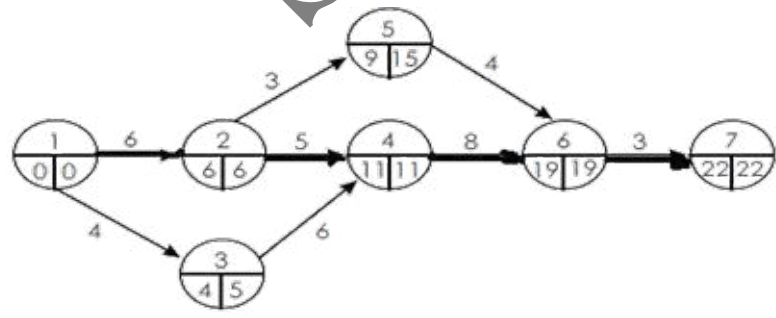

Total Cost = (600 + 600 + 500 + 450 + 900 + 800 + 400 + 450) = ₹4,700

Q5

Dec '23

An engineering firm is tendering for a contract to supply 2 stec) fabrication with target duration of 46 days. The tasks have been analysed as follows:

Activity	Duration (Days)
1-2	10
1-3	12
1-4	10
2-4	9
2-5	13
3-6	17
4-6	12
5-6	14

The firm is awarded the contract and starts work with all activities on their earliest start times but after work on the 15th day there is a fire which destroys all the work -in- progress on task 2-4, 2-5 and 3-6. Fortunately, no other completed tasks are affected but it is estimated that task 5-6 will now need 20 days. The project manager feels that due to fire there will be variability in the task times and has made some uncertainty estimates which are shown as task standard deviation in days:

Activity	Standard Deviation (Days)
2-4	0.82
2-5	1.33
5-6	0.47
4-6	2.17
3-6	1.33

- (i) **Prepare** a PERT network as originally envisaged.
- (ii) **Assess** the new expected project duration and identify the critical path through the remaining activities after the fire,
- (iii) **Evaluate** the probability of the project being completed on time after the fire, [Given area between $Z = 0$ and $Z = 1.42$ is 0.4222]

<p>Reference</p> <p>Network Diagram</p>	<p>What's New</p>
---	--------------------------

Answer

Network Diagram before Fire

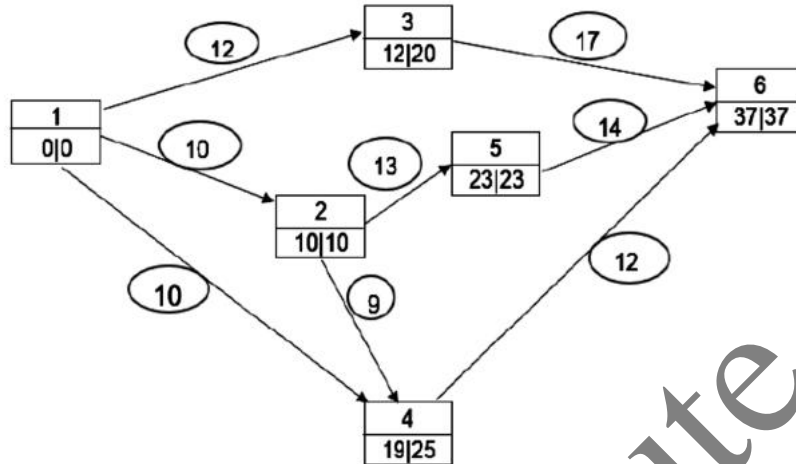

Activities 1-2, 1-3 and 1-4 had already been completed before the fire. After fire, 15 days are over and 31 days (46 days-15 days) remain with the following outstanding activities:

Activity	Duration (Days)
2-4	9
2-5	13
3-6	17
4-6	12
5-6	20

Network Diagram after Fire

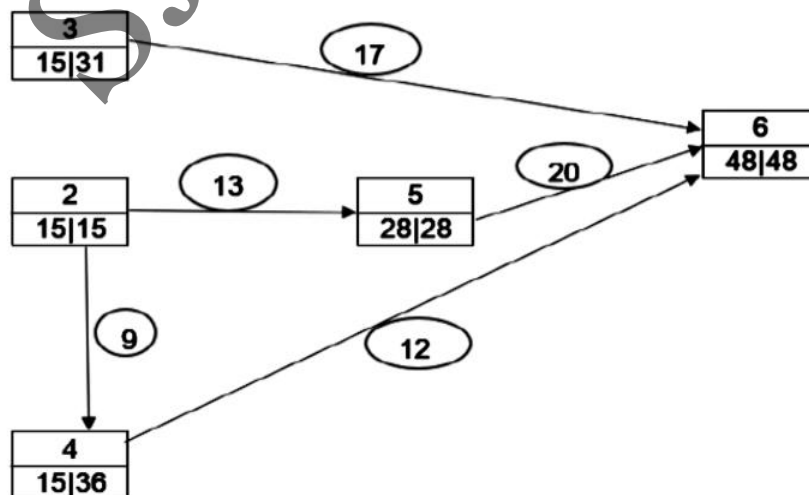

- (ii) New Expected Project Duration is 48 days and Revised Critical Path after fire is 2-5-6.
- (iii) Standard Deviation of the Project = 1.41

Using Z value, we have $Z = -1.42$

Using area under standard normal curve, the probability of achieving 46 days is = 8%

SJC Institute

One-Stop Pass System

For students who needs a push to study with continuous evaluation system but have taken classes haphazardly

SCAN HERE



Sure Shot Batch

आप बस पढाई कीजिए
पूरी PLANNING हमारी

SCAN HERE



BOUNCE BACK ASSESSMENT

To Bounce Back you need to do something different. But what? Take our Bounceback Assessment to know.

SCAN HERE



PREPARATION ASSESSMENT

Know whether you are
on the right track

SCAN HERE



Mock test Sangram

The more you sweat in practice, the less you bleed in Battle

SCAN HERE



Rankers Batch

Are you aiming for a
top rank in exams?
Join our Rankers Batch

SCAN HERE



Chapter 12

Learning Curve

Q1

June'23 MTP Set 1

Z.P.L.C experience difficulty in its budgeting process because it finds it necessary to quantify the learning effect as new products are introduced.

Substantial product changes occur and result in the need for retraining.

An order for 30 units of a new product has been received by Z.P.L.C so far, 14 have been completed; the first unit required 40 direct labour hours and a total of 240 direct labour has been recorded for the 14 units. The production manager expects an 80% learning effect for this type of work.

The company uses standard absorption costing. The costs attributed to the centre in which the unit is manufactured are as follows:

Head	Cost (₹)
Direct Material	₹ 30.00 per unit
Direct Labour	₹ 6.00 per unit
Variable Overhead	₹ 0.50 per direct labour hour
Fixed Overhead	₹ 6,000 per 4 week operating period.

There are ten direct employees working a five-day week, eight hours per day. Personal and other downtime allowances account for 25% of total available time. The company usually quotes a four-week delivery period for orders. You are required to:

Determine whether the assumption of an 80% learning effect is a reasonable one in this case, by using the standard formula $Y = ax^b$

Where Y = the cumulative average direct labour time per unit (productivity). a = the average labour time per unit for the first batch.

x = the cumulative number of batches produced. b = the index of learning.

- Calculate** the number of direct labour hours likely to be required for an expected second order of 20 units.
- Use the cost data given to produce an estimated product cost for the initial order, **examine** the problems.

Use logarithmic tables to find the values of Logarithm and Anti-Logarithm.

[4 + 4 = 8]

<p>Reference</p> <p>Direct Labour Hours, Estimated Product Cost</p>	<p>What's New</p>
---	--------------------------

Answer

Total time taken to produce 14 units

$$Y = ax^b$$

$$Y = 40 (14)^{-0.322}$$

$$\log Y = \log 40 - (0.322) \log 14$$

$$= 1.60221 - (0.322) \times 1.1461$$

$$= 1.60221 - 0.3690 = 1.233$$

$$Y = \text{Antilog } (1.233) = 17.14$$

$$\text{Total time} = 17.14 \times 14 = 239.96$$

$$= 240 \text{ hours (which is same as the hours recorded)}$$

So the assumption that learning ratio 80% is reasonable.

(i) 30 units

$$Y = 40 (30)^{-0.322} = 13.380 \text{ hours (Average time)}$$

50 units

$$Y = 40 (50)^{-0.322} = 11.35 \text{ hours (Average time)}$$

$$\text{Total time for 30 units} = 13.38 \times 30 = 401.4 \text{ hours}$$

$$\text{Total time for 50 units} = 11.35 \times 50 = 567.5 \text{ hours}$$

$$\text{Time taken for 20 units from 31 to 50 units } (567.5 - 401.4) = 166.1 \text{ hours}$$

(ii) Man hours = $10 \times 8 \times 5 \times 4 = 1600$

(-) down time (25% × 1600) = 400

1200

Fixed Cost per hour = $6000/1200 = ₹ 5$

Computation of total cost for the initial order

Material (30 × 30) = ₹ 900.0

Labour (401.4 × 6) = ₹ 2408.4

Variable Overheads (0.5 × 401.4) = ₹ 200.7

Fixed Overheads (5 × 401.4)	= ₹ 2007.0
Total Cost	<u>= ₹ 5516.1</u>

Q2

June'23 MTP Set 2

Human performance of activities typically shows improvement when the activities are done on a repetitive basis. The time required to perform a task decreases with increasing repetitions. The degree of improvement and the number of repetitions needed to realize the major portion of the improvement is a function of the task being done. If the task is short and somewhat routine, only a modest amount of improvement is likely to occur and it generally occurs during the first few repetitions. If the task is fairly complex and has a longer duration, improvements will occur over a large number of repetitions.

Any kind of surgery comes under the category of fairly complex or complex task. Surgeons require large number of repetitions of a particular type of surgery to master it. This is due to the fact that random complications may arise due to the patients' conditions. Hence it is important to know the number of repetitions required for a surgeon to stabilize the operating times and the complication rates.

Dr. X of ABC Hospital reported the results of 100 consecutive operations for laparoscopic hernia repair on 98 patients. Approximately two thirds of the surgeries were unilateral (left / right) and the remaining one third were bilateral involving contra lateral defects, many unsuspected before surgery. The average surgery time (from skin incision to skin closure) was 46 minutes for unilateral and 62 minutes for bilateral. Surgery times for the unilateral procedure began to level off after 50 operations. The average surgery times (in minutes) reported by the doctor for each quartile of the 100 operations, classified by the type of operation are as provided in the table below

Type of Surgery	1st Quartile	2nd Quartile	3rd Quartile	4th Quartile
Unilateral	59	45	38	37
Bilateral	69	67	58	52

At the end of the study the times had levelled off at 58 minutes (operating time) including 37 minutes of surgical time for Unilateral type which are considered to be the historical times for open repair. Complication rates were also reduced in an approximately exponential manner, beginning to level off at 50 operations and becoming stable after 75. It is also reported that the 1st to 4th quartile of the Unilateral type surgery are represented by the 8th, 24th, 40th and 58th observations respectively and those of Bilateral are 4th, 12th, 20th and 28th observations respectively.

- (1) **Analyse** the incidence described above and formulate a set of brief explanations to ascertain which particular phenomenon of human behaviour the above incidence refers to?
- (2) **How** you can decide which one of the two types of surgeries was grasped faster by the surgeon? Explain.

- (3) **What** type of relationship exists between the Average time required to complete a particular operation with the number of operations done by the surgeon?
- (4) **Design** with brief reasons the procedure to determine the time required by the surgeon to complete 59th Unilateral type surgery and 27th Bilateral type surgery. [8]



Reference

Comments on Learning

What's **New**

Answer

- (1) The described information refers to the LEARNING phenomenon of human beings. The data provided show a continuous reduction of Operating time for both types of surgeries. In other words, there is a continuous improvement in the performance of a human being (the Surgeon) with repetition of the task. This happens only due the Learning effect.
- (2) To understand the grasping rate of the surgeon for any type of surgery one has to find out his LEARNING PERCENTAGE for that type of surgery from the supplied data. Higher is the numerical value of the Learning Percentage for a particular type, faster is said to be the grasping rate for that.
- (3) If T_N be the Average time required to complete the nth operation and T_1 be that of the first one then the relation between T_N and N (the number of operations done) is given as follows -

$$T_N = T_1 \cdot N^b \text{ where } b = \text{Learning Index} = \log(\text{Learning Percentage}/100) \div \log 2$$

Thus an Exponential relation exists between the Average time required to complete an operation and the number of operations done by the surgeon.

- (4) From the basic concept of Learning we can say –

Time required to complete the Nth operation (t_N) = Difference between the total time required for N operations and (N - 1) operations

Now total time required for N operations = $N \cdot T_N$ where T_N represents the Average time per operation when N operations are done.

$$\text{Thus } t_N = N \cdot T_N - (N - 1) \cdot T_{(N-1)}$$

So for the Unilateral type, $t_{59} = 59 \cdot T_{59} - 58 \cdot T_{58}$ where the values of T_{59} and T_{58} are to be computed from the supplied data for Unilateral type.

Similarly for Bilateral type, $t_{27} = 27 \cdot T_{27} - 26 \cdot T_{26}$

Q3

June'23

GANGOTRI LTD. is developing a new product. During its expected life, 16,000 units of the product will be sold for ₹ 102 per unit. Production will be in batches of 1,000 units throughout the life of the product. The direct labour cost is expected to reduce due to the effects of learning for the first eight batches, produced. Thereafter, the direct labour cost will remain constant at the same cost per batch as in the 8th batch.

The direct labour cost of the first batch of 1,000 units is expected to be ₹ 55,000 and a 90% learning effect is expected to occur. The direct material and other non-labour related variable costs will be ₹ 50 per unit throughout the life of the product.

There are no fixed costs that are specific to the product.

[Given: The learning index for a 90% learning curve = - 0.152; $8^{-0.152} = 0.729$;

$7^{-0.152} = 0.744$; $9^{-0.152} = 0.716$ and $4\sqrt{0.4532} = 0.8205$, $4\sqrt{0.3773} = 0.7837$, $4\sqrt{0.2636} = 0.7166$]

Required:

- Calculate** the expected direct labour cost of the 8th batch,
- Assess** the expected contribution to be earned from the product over its lifetime.
- Infer the rate of learning required to achieve a lifetime product contribution of 6,00,000, assuming that a constant rate of learning applies throughout the product's life. [3+2+3=8]

Reference

Use of Learning Curve Equation - Direct Labour Cost, Contribution, Rate of Learning

What's New

Answer

(a) D/L Cost of 8th Batch

$$\begin{aligned} \text{First 8 batches } Y &= K \times x^5 = 55,000 \times 8^{-0.152} \\ &= 55,000 \times 0.729 \end{aligned}$$

$$= 40,095/\text{batch}$$

$$\begin{aligned} \text{First 7 batches} &= 55,000 \times 7^{-0.152} \\ &= 55,000 \times 0.744 \end{aligned}$$

$$= 40,920/\text{batch}$$

$$\begin{aligned} \text{For 8th batch} &= 40,095 \times 8 - 40,920 \times 7 \\ &= 34,320 \end{aligned}$$

(b) Expected Contribution

Sales	102 × 16,000
(-) D/M	50 × 16,000
D/L	First 8 × 40095
	Next 8 × 34300
	2,36,680

(c) Learning Rate

Sales	16,32,000
(-) D/M	8,00,000
D/L	2,32,000
Contribution	6,00,000

$$16 \times r^4 \times 55,000 = 2,32,000; r = 0.7166 = 71.66\%$$

Q4

MTP Dec'23 Set 1

The usual learning curve model is $Y = ax^b$ where

Y is the average time per unit for x units.

a is the time for first unit

x is the cumulative number of units b is the learning coefficient and is

equal to $\frac{\log 0.8}{\log 2} = -0.322$ for a learning rate of 80%

Given that a = 10 hours and learning rate 80%.

You are **required** to **Calculate**:

- (i) The average time for 20 units.
- (ii) The total time for 30 units.
- (iii) The time for units 31 to 40.

Given that $\log 2 = 0.301$, Antilog of 0.5811 = 3.812
 $\log 3 = 0.4771$, Antilog of 0.5244 = 3.345.
 $\log 4 = 0.6021$, Antilog of 0.4841 = 3.049

Reference

Use of Learning Curve Equation, Log & Antilog
What's **New**
Answer

(i) $Y = AX^b$

$$Y = 10(20)^{-0.322}$$

Taking log on both sides

$$\text{Log } y = \text{log } 10 + \text{log } 20^{(-0.322)}$$

$$\text{Log } y = \text{log } 10 - (0.322) \text{log } 20$$

$$= 1 - (0.322) \text{log } 20$$

$$= 1 - (0.322) \times (1.3010)$$

$$= 1 - 0.41892 = 0.5811$$

$$\text{Log } y = 0.5811$$

$$Y = \text{Anti log } (0.5811) = 3.812 \text{ hrs (average time)}$$

$$\text{Total Time} = 3.812 \times 20 = 76.24 \text{ hours}$$

(ii) $\text{Log } y = \text{log } 10 + \text{log } 30^{(-0.322)}$

$$\text{Log } y = 1 - (0.322) \times (1.4771)$$

$$= 1 - (0.4756) = 0.5244$$

$$Y = \text{anti log } (0.5244) = 3.345 \text{ hrs (average time)}$$

$$\text{Total time} = 3.345 \times 30 = 100.35 \text{ hrs}$$

(iii) $\text{Log } y = \text{log } 10 + \text{log } 40^{(-0.322)}$

$$= 1 - (0.322) \times (1.6021) \text{Log } y = 0.4841$$

$$Y = \text{anti log } (0.4841) = 3.049 \text{ hrs Total time} = 40 \times 3.049 = 121.96 \text{ hrs}$$

$$\text{Time from 31 to 40 units} = 121.96 - (100.35) = 21.61 \text{ hrs}$$

Q5

Dec '23

Heavy India Shipbuilders produce a special type of boat to be used by a shipping company. A 90% learning curve is expected to apply to production of this type of boat. It is agreed that boats will be supplied at variable cost plus 20%. The variable cost of the first boat to be produced has been estimated as follows:

	₹
Materials	8,000
Labour (1000 hrs @ % 4 per hour)	4,000
Variable Overhead (200% of direct labour)	8,000

Order will be for a minimum of 2 boats.

- (1) **Find** the average selling price per boat if the order is for 4 boats and 8 boats.
- (2) Also **ascertain** the separate selling price for 3rd and 4th boats. [7]

<p>Reference</p> <p>Average selling price</p>	<p>What's New</p>
---	--------------------------

Answer

Selling Price

	For 4 Boats (₹)	For 8 Boats (₹)
Selling Price / Boat	21,264	20,097.63

Price for 3rd and 4th Boats:

	Amount (₹)
Selling Price / Boat	19,968

Every student is different

SJC HAS METHODS TO TEACH EVERY TYPE OF STUDENT

For Top-performing students Who are disciplined, sincere, and confident.

ONLY CLASSES

For self-disciplined, sincere, students who seek reassurance for improvement.

CLASSES + MOCK TEST

For students who needs a push to study with continuous evaluation system but have taken classes haphazardly

ONE STOP PASS SYSTEM

For students who start early & want to stay organized from day one

SURE SHOT BATCH

SCAN HERE

Become Our ROCKET STUDENT

Register for full group of any level of CA-CMA-CS & get the following **BENEFITS** :

- 01** 1 to 1 Preparation Assessment worth Rs. 2499/-
- 02** 10% OFF on Next Group Combo
- 03** 10% OFF on Group Mock Test Sangram (MTS)
- 04** 10% OFF on One Stop Passing System (OSPs)
- 05** 5% MONEY BACK for every Referral you give us

SCAN HERE

CA/CMA INTERNSHIP WORKSHOP

What we will cover?

- Importance of Internship?
- How it will help you in real world?
- How to start?
- Which area is good for you?

SCAN HERE

CA Girish Ganeriwala
CA Satish Jalan

FINANCE PRACTICAL TRAINING BASIC COURSE

Journey from Learning to Understanding

Grow yourself in any sphere by gaining the Confidence over the Numbers

SCAN HERE

CA Girish Ganeriwala
CA Satish Jalan

Business Application of Maxima and Minima

Q1

June'23 MTP Set 1

Assume the Cost in Rupee term for manufacturing x number of a product per day is $C(x) = 14400 + 550x + 0.01x^2$.

Suggest the no. of units of the product that should be manufactured per day so that the Average Cost is minimum. Also **find** the Average Cost and the total cost at this level of production. [6]

Reference

What's New

No. of Units, Average Cost, Total Cost

Answer

Cost function is given to be $C(x) = 14400 + 550x + 0.01x^2$

So Average Cost function = $C(x) / x$

Or, $AC(x) = (14400 + 550x + 0.01x^2) / x$

Or, $AC(x) = 14400/x + 550 + 0.01x$

This is the Objective function which has to be minimized.

Differentiating both sides of the above function with respect to 'x' we get

$$\frac{d}{dx} [AC(x)] = 14400/x^2 + 0.01 \quad (i)$$

As per the necessary condition of optimization, $\frac{d}{dx} [AC(x)] = 0$

$$\text{or, } -14400/x^2 + 0.01$$

$$\text{or, } 0.01x^2 = 14400$$

$$\text{or, } x^2 = 14400/0.01$$

$$\text{Or, } x = \pm \sqrt{1440000}$$

$$\text{Or, } x = \pm 1200$$

But x being the quantity cannot be negative. Hence $x = 1200$

To ascertain whether this value of x corresponds to minima, we have to take help of the sufficient condition mentioned above.

Again differentiating both sides of 9i) with respect to 'x' we get, $\frac{d^2}{dx^2}[AC(x)]$
 $= 28800/x^3$

For $x = 1200$, the value of 2nd order Derivative is $\frac{d^2}{dx^2} [AC(1200)] = 28800/(1200)^3$
 $= 1.67 \times 10^{-5} > 0$

So there exist a Minima to the Objective Function at $x = 1200$

Hence 1200 units should be produced per day to minimize the Average Cost. At this level of production,

Average Cost = $[AC(X)]$ at $x = 1200$
 $= 14400/1200 + 550 + 0.01 \times 1200$
 $= ₹ 574$ per unit

Also at this level of production,

Total Cost = $[C(x)]$ at $x = 1200$
 $= 14400 + 550 \times 1200 + 0.01 \times 1200^2$
 $= ₹ 6,88,800/-$

Q2

June'23 MTP Set 2

A company produces two products x and y . The total Profit (in ₹ '000) earned by the company is expressed algebraically by the function $\Pi = 100x - x^2 - 2xy + 200y - 3y^2$. Critically assess the Profit maximizing quantities of the products.

Also **determine** the maximum profit with justification in support of your determined value. [7]

<p>Reference</p> <p>Maximum Profit</p>	<p>What's New</p>
--	--------------------------

Answer

Profit function is given as: $\Pi = 100x - x^2 - 2xy + 200y - 3y^2$

Differentiating the function partially with respect to x we get,

$$\Pi_x = 100 - 2x - 2y \quad (I)$$

Also differentiating the function partially with respect to y we get

$$\Pi y = -2x + 200 - 6y \quad (II)$$

To determine the Critical Point, we have $\Pi x = 0$ and $\Pi y = 0$

$$\text{So, } 100 - 2x - 2y = 0 \text{ Or. } x + y = 50 \text{ ---(1) and } -2x + 200 - 6y = 0 \text{ or, } x + 3y = 100 \quad (2)$$

(2) - (1) gives, $2y = 50$ or, $y = 25$ Putting $y = 25$ in (1) we get $x = 25$

Thus Critical Point is (25, 25)

To check whether this point is a local Maxima, we have to find out the values of the 2nd Order Partial Derivatives at this point.

Again differentiating (I) partially with respect to x we get $\Pi xx = -2$ Or, $A = -2$ (Let) Or, $A < 0$

Similarly differentiating (II) partially with respect to y we get $\Pi yy = -6$ Or, $C = -6$ (Let) or, $C < 0$

Also differentiating (I) partially with respect to y we get $\Pi xy = -2$ Or, $B = -2$ (Let) So $D = AC - B^2 = (-2) \times (-6) - (2)^2 = 8 > 0$

Hence $D > 0$ and $A, C < 0$

Thus there is a local Maxima at the already determined Critical Point (25, 25)

Required Profit maximizing quantities of the products are $x = 25$ units and $y = 25$ units. Also Maximum profit = Value of the function Π at $x = 25$ & $y = 25 = 100 \times 25 - 25^2 - 2 \times 25 \times 25 + 200 \times 25 - 3 \times 25^2 = ₹3,750$ (₹000)

Q3

June'23

The total cost function of a firm

$$C = \frac{x^3}{3} - 5x^2 + 28x + 10,$$

Where C is total cost and ' x ' is the output, A GST @ ₹2 per unit of output is imposed and the producer adds it to his cost. If the demand function is given by $D = 2530 - 5x$, where D is the price per unit of output.

Required:

Evaluate the profit maximizing output and the price at the level.

[6]



Reference

Profit Maximizing Output

What's **New**

Answer

Maximum profit is at 50 units

Price = ₹ 2,280

Become Our **ROCKET STUDENT**

Register for **full group** of any level of **CA-CMA-CS** & get the following **BENEFITS**:

01

1 to 1 Preparation Assessment worth **Rs. 2499/-**

02

10% OFF on Next Group Combo

03

10% OFF on Group Mock Test Sangram (MTS)

04

10% OFF on One Stop Passing System (OSPS)

05

5% MONEY BACK for every Referral you give us

- You may choose from **any faculties** on SJC Website
- If you have registered only one subject, then you may register other subjects of the same group **within 15 days** to claim these benefits

Please connect with us at **8100 11 2222** with your registration details to know more



Business Forecasting Models (Time Series and Regression Analysis)

Q1

Postal Test Paper

M/S B.P. Leathers, a shoe manufacturer has modern outlook and they depend heavily on Business Forecasting methodology to plan their business activities like manufacturing, marketing, finance etc. At the beginning of the year 2022 they have forecasted data of demand of their shoes for the beginning of the month of March as 1000 pairs. But the actual demand turned out to be 900 pairs. Using a Smoothing Coefficient of 0.1 **forecast** the demand at the beginning of the 2nd week of March 2022.

Also **forecast** the demands using Exponential Smoothing technique at the beginning of each week till mid-April 2022 when the actual demands are as follows –

At the beginning of the 2nd week of March – 1010 pairs, At the beginning of the 3rd week of March – 1032 pairs, At the beginning of the 4th week of March – 976 pairs, At the beginning of the 1st week of April – 934 pairs, At the beginning of 2nd week of April – 1008 pairs & At the end of the 2nd week of April – 1020 pairs.

<p>Reference</p> <p>Exponential Smoothing</p>	<p>What's New</p>
---	--------------------------

Answer

As per the concept of Exponential Smoothing we have $u_t = u_{t-1} + \alpha e_t$ where $e_t = y_t - u_{t-1}$
= Forecast Error & $\alpha = 0.1$

Calculations for Exponential Smoothing

Beginning of	Demand of shoe (y_t in Pairs)	Previous Forecast (u_{t-1})	Forecast Error ($e_t = y_t - u_{t-1}$)	Correction (αe_t) ($\alpha = 0.1$)	New Forecast ($u_t = u_{t-1} + \alpha e_t$)
March 1st week	900	1000	- 100	- 10	990
March 2nd week	1010	990	20	2	992
March 3rd week	1032	992	40	4	996

March 4th week	976	996	- 20	- 2	994
April 1st week	934	994	- 60	- 6	988
April 2nd week	1008	988	20	2	990
April 2nd week end or Mid April	1020	990	30	3.0	993

[Note – Except the 1st entry of 3rd column, all the other entries are taken from the last column].

Q2

June'23 MTP Set 2

From the following past data of Sales (in lakhs rupees) of a company estimate the same for the year 2025.

Year	2010	2011	2012	2013	2014	2015	2016	2017	2018	2019
Sales	15.3	14.6	16.8	17.3	17.2	20.9	22.3	20	23.1	24.5

Assume the trend line to be linear. **What** is the monthly rate of increase of sales? [7]

<p>Reference</p> <p>Straight Line Trend, Monthly Rate of Increase of Sales</p>	<p>What's New</p>
--	--------------------------

Answer

Let the best fit Linear Trend line to the given data be $y = a + bx$ (origin at the middle of the year 2014 & 2015 and x unit = 6 months)

Normal equation are $\sum y = a.n + b.\sum x$ (1) where $n = \text{No. of years} = 10$ (here)

$$\sum xy = a.\sum x + b.\sum x^2 \quad (2)$$

Using the values (from calculations below) of $\sum y$, $\sum x$ and n is equation (1) we get,

$$192 = a.10 + b.0$$

$$\text{Or, } a = 19.2$$

Also using the values (from calculations below) of $\sum xy$, $\sum x$ and $\sum x^2$ and putting in the equation (2) we get,

$$177 = a.0 + b.330$$

$$\text{Or, } b = 0.536$$

Calculations for fitting Straight Line Trend

Year	Sales (y in ₹ Millions)	x	x ²	xy
2010	15.3	-9	81	-137.7
2011	14.6	-7	49	-102.2
2012	16.8	-5	25	-84
2013	17.3	-3	9	-51.9
2014	17.2	-1	1	-17.2
2015	20.9	1	1	20.9
2016	22.3	3	9	66.9
2017	20	5	25	100
2018	23.1	7	49	161.7
2019	24.5	9	81	220.5
Total	192	0	330	177

So the required equation of Straight Line Trend is $y = 19.2 + 0.536x$ (Origin = At the middle of 2014 & 2015, x unit = 6 months)

For the year 2025, $x = 21$. So the **estimated sales for the year 2025 = $19.2 + 0.536 \times 21 = 30.456$ Million**

Yearly rate of increase in Sales = $b = 0.536$. so **monthly rate of increase in Sales = $b/12 = 0.0467$ Million**

Q3

MTP Dec'23 Set 1

Find trend values of the following year wise data of Goods carried by a fleet of trucks of a Transport Company having pan India network using the Moving Average Method. [Assume a 4 yearly cycle]

Year	1975	1976	1977	1978
Goods carried (Tons)	2204	2500	2360	2680
Year	1979	1980	1981	1982
Goods carried (Tons)	2424	2634	2904	3098
Year	1983	1984	1985	1986
Goods carried (Tons)	3172	2952	3248	3172



Reference
Moving Average Method - Simple Average

What's New
4 Yearly

Answer

Calculations for 4 Yearly Moving Average Trend values

Year	Goods carried (Tons)	4 Yearly Moving Total	4 Yearly Moving Average (Not centred)	2 item Moving Total (Centred)	4 Yearly Moving Average (Centred)
(1)	(2)	(3)	(4) = (3) 4	(5)	(6) = (5) 2
1975	2204	-	-	-	-
1976	2500	-	-	-	-
		9744	2436		
1977	2360			4927	2463.50
		9964	2491		
1978	2680			5015.5	2507.75
		10098	2524.5		
1979	2424			5185	2592.50
		10642	2660.5		
1980	2634			5425.5	2712.75
		11060	2765		
1981	2904			5717	2858.50
		11808	2952		
1982	3098			5983.5	2991.75
		12126	3031.5		
1983	3172			6149	3074.5
		12470	3117.5		
1984	2952			6253.5	3126.75
		12544	3136		
1985	3248	-	-	-	-
1986	3172	-	-	-	-

Q4

Dec '23

The Sales of ZINC in a plant of KHT Ttd. for the years 2014 to 2022 are given below: [7]

Year	2014	2016	2018	2020	2022
Sales of ZINC (in Million%)	36	42	46	54	32

Required:

- (i) Using the method of least squares, analyse a straight line trend value.

(ii) Assess the sale (in Million) of ZINC for the year 2019 and 2025.

Reference	What's New
Straight Line Trend	

Answer

(i) Straight Line Trend $Y_e = 42 + 0.20x$

(ii) Sales (₹ in Million) for:

Year 2019 = ₹ 42.20 Million

Year 2025 = ₹ 43.40 Million

SJC Institute

One-Stop Pass System

For students who needs a push to study with continuous evaluation system but have taken classes haphazardly

SCAN HERE



Sure Shot Batch

आप बस पढाई कीजिए
पूरी PLANNING हमारी

SCAN HERE



BOUNCE BACK ASSESSMENT

To Bounce Back you need to do something different. But what? Take our Bounceback Assessment to know.

SCAN HERE



PREPARATION ASSESSMENT

Know whether you are
on the right track

SCAN HERE



Mock test Sangram

The more you sweat in practice, the less you bleed in Battle

SCAN HERE



Rankers Batch

Are you aiming for a
top rank in exams?
Join our Rankers Batch

SCAN HERE



Introduction to tools for Data Analytics

Q1

June'23 MTP Set 1

- (i) **What** do you mean by Data Mining
- (ii) **Discuss** briefly applications of R Programming in the real world. [3 + 3 = 6]



Reference

Data Mining, Applications of R Programming

What's **New**

Answer

(i) Data Mining

This is the activity of "**Data Discovery**" because here the patterns and inconsistencies of data unveiled through automated or semi-automated data analysis. Common correlations drawn from Data Mining include grouping specific sets of data, finding outliers in data and drawing connections and dependencies from disparate datasets.

Data Mining often **uncovers the patterns used in more complex analyses**, like Predictive modelling which makes it an essential part of the BI Process whose growth is correlated directly with the rise of Big Data in businesses of all sizes.

Of the standard processes performed by Data Mining, **association rule** learning presents the greatest benefit. By examining data to draw dependencies and construct correlations, the association rule can help businesses better understand the way customers interact with their website or even what factors influence their purchasing behavior.

Association rule learning was originally introduced to uncover connections between purchase data recorded in point of sale systems at supermarkets. For example, if a customer purchased Tomato Sauce and Cheese, the association rules would likely uncover that the customer purchased Hamburger Meat as well. Though this is a very simple example but it works well to understand the type of analysis that now connects incredibly complex chains of events in all sorts of industries and helps users find correlations that would have remained hidden otherwise.

(ii) Applications of R Programming in the real world

1. **Data Science** – With the advent of “Internet of things” (IoT) devices creating terabytes and terabytes of data that can be used to make better decisions, Data Science is a field that has no other way but to go up. Simply explained, a data scientist is a statistician with an extra asset – computer programming skills. Programming languages like R give a data scientist superpowers that allow them to collect data in real time, perform statistical and predictive analysis, create visualisation and communicate actionable results to the stakeholders.
2. **Statistical Computing** – R is the most popular programming language among statisticians. In fact, it was initially built by statisticians for carry work related to statistical data. It has a rich package repository with over 9000 packages having every statistical function one can think of. R’s expressive syntax allows researchers – even those from non- computer science backgrounds to quickly import, clean and analyse data from various data sources. R also has charting capabilities which means one can plot the data and create interesting visualisations from any dataset.
3. **Machine Learning** – R has found a lot of use in predictive analytics and machine learning. It has various packages for common ML tasks like linear and nonlinear regression, decision trees, linear and non- linear classification and many more. Everyone from machine learning enthusiasts to researchers use R to implement machine learning algorithms in fields like finance, genetics research, retail, marketing and health care.

Q2

Postal Test Paper

What are the different types of Data Analysis Tool?

[6]

<p>Reference Data Analysis tool</p>	<p>What's New</p>
---	--------------------------

Answer

Data Analysis Tools

These tools are meant for Analysis part of the data. Broad classification of these tools are –

- Spread-sheets
- Business Intelligence (BI) tools
- Financial data Analytics tools

- Programming Languages
- Tools for Statistical Data Analysis
- Industry Specific tools

Q3

June'23

- (i) **What** do you mean by Business Intelligence (BI) software?
- (ii) **Discuss** in brief what are the features of R Programming Language.

<p>Reference</p> <p>Business Intelligence; R Programming Language</p>	<p>What's New</p>
--	--------------------------

Answer

- (i) **Business Intelligence (BI)** Software is a set of business analytics solutions used by companies to retrieve, analyse and transform data into useful business insights usually within easy-to-read visualization - like charts, graphs and dashboards. Examples of the best BI Tools include data visualization, data warehouses, interactive dashboards and BI reporting tools. A BI Solution pulls internal data produced by a company, into an Analytics platform for deep insights as to how different parts of a business affect one another.

As Big Data has gained in prominence, the tendency for companies to collect, store and mine their business data has increased many times and so has the popularity of BI Software. Companies generate, track and compile business data at a scale never seen before. The ability to integrate cloud software directly with proprietary systems has further driven the need to combine multiple data sources and take advantage of data preparation tools. But all this data is nothing if we can't make sense of it and use it to improve business outcomes.

To make informed choices, businesses need to make their decisions on evidence. The mountains of data that businesses and their customers produce contain evidence of purchasing patterns and market trends. By aggregating, standardising and analysing that data, businesses can better understand their customers, better forecast their revenue growth and better protect themselves against business pitfalls.

Business intelligence has traditionally taken the form of quarterly or yearly reports that report on a defined set of Key Performance Indicators (KPI). But today's BI Reporting software is backed by Data Analytics tools that work continuously at the speed of light. These insights can help a company take a course of action within minutes.

BI Software interprets a sea of quantifiable customer and business actions and returns queries based on patterns in the data. BI comes in many forms and spans, many different types of technology.

The chart below shows a comparison of few top Business Intelligence Tools according to user popularity and major features.

(ii) Features of R Programming language

1. Statistical features of R:

- **Basic Statistics** – Most common terms of basic statistics are Mean, Median and Mode which are the Measures of Central Tendency for a dataset. These can be very easily computed using R.
- **Static Graphics** – R is rich with facilities for creating and developing interesting Static Graphics. R contains functionality for many plot types including graphic maps, mosaic plots, bi-plots and the list goes on.
- **Probability Distributions** – Probability Distributions play vital role in statistics. By using R various types of problems related to probability distributions (such as Binomial Distribution, Normal Distribution, Student's t Distribution, Chi Square Distribution etc.) can be handled very easily.
- **Data Analysis** – It provides a large, coherent and integrated collection of tools for data analysis.

2. Programming features of R:

- **R Packages** – One of the major features of R is the fact that it has a wide availability of libraries. R has CRAN (Comprehensive R Archive Network) which is repository holding more than 10,000 packages.
- **Distributed Computing** – Distributed computing is a model in which components of a software system are shared among multiple computers to improve efficiency and performance. Packages like ddR and multidplyr are used for distributed programming in R.

Every student is different

SJC HAS METHODS TO TEACH EVERY TYPE OF STUDENT

ONLY CLASSES
For Top-performing students Who are disciplined, sincere, and confident.

CLASSES + MOCK TEST
For self-disciplined, sincere, students who seek reassurance for improvement.

ONE STOP PASS SYSTEM
For students who needs a push to study with continuous evaluation system but have taken classes haphazardly.

SURE SHOT BATCH
For students who start early & want to stay organized from day one.

SCAN HERE

Become Our ROCKET STUDENT

Register for full group of any level of CA-CMA-CS & get the following **BENEFITS** :

- 01** 1 to 1 Preparation Assessment worth Rs. 2499/-
- 02** 10% OFF on Next Group Combo
- 03** 10% OFF on Group Mock Test Sangram (MTS)
- 04** 10% OFF on One Stop Passing System (OSPs)
- 05** 5% MONEY BACK for every Referral you give us

SCAN HERE

CA/CMA INTERNSHIP WORKSHOP

What we will cover?

- Importance of Internship?
- How it will help you in real world?
- How to start?
- Which area is good for you?

SCAN HERE

CA Girish Ganeriwala
CA Satish Jalan

FINANCE PRACTICAL TRAINING BASIC COURSE

Journey from Learning to Understanding

Grow yourself in any sphere by gaining the Confidence over the Numbers

SCAN HERE

CA Girish Ganeriwala
CA Satish Jalan

Chapter 16

Multiple Choice Questions

MTP June'23 (Set 1)

- (i) The cost incurred to ensure that failures do not happen is known as _____. Provide a justification for your answer.
- External failure cost
 - Internal failure cost
 - Prevention cost
 - None of the above
- (ii) Which of the following is not the quality parameter for service organizations and why?
- Consistency
 - Friendliness
 - Durability
 - Promptness
- (iii) Which one of the following is not a standard definition of 'Quality' and why?
- Conformance to Specifications
 - Fitness for Use
 - Psychological Criteria
 - Physiological Criteria
- (iv) Prevention costs are all costs incurred in the process of preventing poor quality from occurring. Which one of the following is not included in Prevention cost? Provide a justification.
- Cost of creating and maintaining quality circles
 - Cost related to statistical process control activities
 - Costs related to System Development for prevention
 - WIP testing and inspecting

- (v) The best way to define the principles that guide Lean Accounting and form the foundation for all of accounting's work and interaction with the organization are _____. Provide a justification for your answer.
- Customer value:
 - Continuous improvement:
 - Respect for people:
 - All of the above.
- (vi) A company is considering to accept a one-year contract which will require four skilled employees. The four skilled employees could be recruited on a one-year contract at a cost of ₹ 40,000 per employee. The employees would be supervised by an existing manager who earns ₹ 60,000 per annum. It is expected that supervision of the contract would take 10% of the manager's time.
- Instead of recruiting new employees, the company could retrain some existing staff who currently earns ₹30,000 per year. The training would cost ₹15,000 in total but if those employees were used they would need to be replaced at a total cost of ₹100,000. The relevant labour cost of the contract is _____.
- ₹ 1,15,000
 - ₹1,00,000
 - ₹ 85,000
 - ₹ 1,10,000
- (vii) A firm has some material which originally cost ₹ 45,000. It has a scrap value of ₹12,500 but if reworked at a cost of ₹ 7,500 it could be sold for ₹17,500. What would be the incremental effect of reworking and selling the material?
- A Loss of ₹ 27,500
 - B Loss of ₹2,500
 - C Profit of ₹ 5,000
 - D Profit of ₹10,000
- (viii) The product of XYZ Company is sold at a fixed price of ₹1,500 per unit. As per company's estimate, 500 units of the product are expected to be sold in the coming year. If the value of investments of the company is ₹15 lakhs and it has a target ROI of 15%, the target cost would be _____.
- ₹ 930
 - ₹ 950
 - ₹ 1,050
 - ₹ 1,130

Solution :

Sl. No.	Answer	Justification
(i)	c	Cost to ensure that failure does not happen is for ensuring that in future failure is prevented.
(ii)	c	Service organizations produce a product that is intangible. Usually, the complete product cannot be seen or touched. Rather, it is experienced. Examples include delivery of health care, experience of staying at a vacation resort, and learning at a university. Thus durability cannot be a parameter of quality of Service organization.
(iii)	d	(i) Today, there is no single universal definition of quality. Some people view quality as "performance to standards." Others view it as "meeting the customer's needs" or "satisfying the customer." Some of the more common definitions of quality are; a. Conformance to Specifications: b. Fitness for Use c. Value for Price Paid d. Support Services e. Psychological Criteria Thus Physiological Criteria is certainly not one of the standard definitions of Quality.
(iv)	d	The first category of quality cost consists of costs necessary for achieving high quality, which are also called quality control costs. These are either prevention cost or appraisal cost. While prevention costs are all costs incurred in the process of preventing poor quality from occurring appraisal costs are incurred in the process of uncovering defects. They include the cost of quality inspections, product testing, and performing audits to make sure that quality standards are being met. Thus it is quite evident that WIP testing and inspecting is appraisal cost and not prevention cost.

(v)	d	<p>(i) Three principles guide Lean Accounting and form the foundation for all of accounting's work and interaction with the organization:</p> <p>a. Customer value: Delivering the relevant and reliable information in a timely manner to all users of the information inside the organization.</p> <p>b. Continuous improvement: Improving accounting processes, cross-functional business processes and the information used inside the business for analysis and decision making.</p> <p>c. Respect for people: Adopting a learning attitude by seeking to understand root causes of business problems and issues in a cross-functional, collaborative manner.</p> <p>Thus the best way of defining the principles of Lean Accounting are all of the above.</p>						
(vi)	a	<p>(i) The relevant cost in this example is the lower of the relevant cost for each option</p> <p>Recruitment</p> <p>Four employees @ ₹ 40,000 each = ₹160,000 (Super vision is sunk as it is already incurred)</p> <p>Retrain and replace</p> <table style="margin-left: 20px;"> <tr> <td>Training</td> <td style="text-align: right;">₹ 15,000</td> </tr> <tr> <td>Replacement</td> <td style="text-align: right;">₹1,00,000</td> </tr> <tr> <td></td> <td style="text-align: right;">₹ 1,15,000</td> </tr> </table> <p>So answer is ₹ 1,15,000</p>	Training	₹ 15,000	Replacement	₹1,00,000		₹ 1,15,000
Training	₹ 15,000							
Replacement	₹1,00,000							
	₹ 1,15,000							
(vii)	b	<p>B (incremental approach)</p> <p>Option 1</p> <p>Sell for scrap ₹ 12,500</p> <p>Option 2</p> <table style="margin-left: 20px;"> <tr> <td>Extra cost</td> <td style="text-align: right;">7,500</td> </tr> <tr> <td>Extra revenue</td> <td style="text-align: right;">5,000</td> </tr> <tr> <td>Loss</td> <td style="text-align: right; border-top: 1px solid black; border-bottom: 3px double black;">2,500</td> </tr> </table>	Extra cost	7,500	Extra revenue	5,000	Loss	2,500
Extra cost	7,500							
Extra revenue	5,000							
Loss	2,500							

(viii)	c	<p>Target ROI at 15% of total investment of ₹ 15 lakhs</p> $= ₹ 15,00,000 \times 0.15$ $= ₹ 2,25,000$ <p>Expected output = 500 units</p> <p>Target Profit per unit of output = ₹ 2,25,000 ÷ 500</p> $= ₹ 450 \text{ per unit}$ <p>Target cost per unit = Selling Price – Profit per unit</p> $= ₹ 1,500 - ₹ 450$ $= ₹ 1,050 \text{ per unit}$
--------	---	---

SJC Institute

MTP June'23 (Set 2)

(i) Which one of the following is not true for a Blue Ocean Strategy?

- a. Create uncontested market space
- b. Make the competition irrelevant
- c. Exploit existing demand
- d. Create and capture new demand

Briefly state a reason supporting your selection.

(ii) One of the following is not an advantages of cost control are mainly as:

- a. Achieving the expected return on capital employed by maximizing or optimizing profit.
- b. Increasing the productivity of the available resources.
- c. Delivering the product or service to the customers at a reasonable price.
- d. It is a corrective function, thus corrects an existing situation.

Briefly justify your answer.

(iii) The rules governing the application of the Value Analysis (VA) approach are

- a. No cost can be removed if it compromises the quality of the product or its reliability.
- b. Marketability is another issue that cannot be compromised.
- c. Any activity that reduces the maintainability of the product increases the cost of ownership to the customer and can lower the value attached to the product.
- d. None of the above

Briefly state a reason in support of your selection.

(iv) Which of the following is not a term normally used in value analysis and why?

- a. Exchange value
- b. Use value
- c. Esteem value
- d. Cost value

(v) Which of the three principles guide Lean Accounting and form the foundation for all of accountants' work and interaction with the organization and why?

- a. Customer value, quality circle, respect for people
- b. Supplier value, quality circle, respect for people
- c. Customer value, continuous improvement, respect for people
- d. Supplier value, continuous improvement, suggestion box

(vi) The standard variable production overhead cost of product B is as follows.

4 hours at ₹ 1.70 per hour = ₹ 6.80 per unit

During period 3 the production of B amounted to 400 units. The labour force worked 1,690 hours, of which 30 hours were recorded as idle time. The variable overhead cost incurred was ₹ 2,950. The variable production overhead efficiency variance for period 3 is

- a. ₹ 102 (F)
- b. ₹ 102 (A)
- c. ₹ 105 (A)
- d. ₹ 153 (A)

(vii) M Co sells product L. An extract from its budget for the four-week period ended 28 October 2022 shows that it planned to sell 500 units at a unit price of ₹ 300, which would give a C/S ratio of 30%. Annual sales were 521 units at an average selling price of ₹ 287. The actual C/S ratio averaged 26%. The sales volume contribution variance (to the nearest ₹ 1) was

- a. ₹ 1,890 (F)
- b. ₹ 1,808 (F)
- c. ₹ 1,638 (F)
- d. ₹ 1,567 (F)

(viii) A technical writer is to set up her own business. She anticipates working a 40-hour week and taking four weeks' holiday per year. General expenses of the business are expected to be ₹ 10,000 per year, and she has set herself a target of ₹ 40,000 a year salary. Assuming that only 90% of her time worked will be chargeable to customers, her charge for each hour of writing (to the nearest cent) should be

- a. ₹ 26.04
- b. ₹ 30.94
- c. ₹ 28.94
- d. ₹ 29.84

Solution :

Sl. No.	Answer	Justification
(i)	(c)	Blue ocean strategists recognize that market boundaries exist only in managers' minds, and they do not let existing market structures limit their thinking. To them, extra demand is out there, largely untapped. Thus exploiting existing markets [C] cannot be an option.
(ii)	(d)	The advantages of cost control are <ul style="list-style-type: none"> • The advantages of cost control are mainly as follows: • Achieving the expected return on capital employed by maximizing or optimizing profit. • Increasing the productivity of the available resources. • Delivering the product or service to the customers at a reasonable price. • Continued employment and job opportunity for the workers • Economic use of limited resources of production • Increased credit worthiness • Prosperity and economic stability of the industry Thus it is clear that cost control is not a corrective function. Point D is the answer
(iii)	(d)	The key focus of the Value Analysis (VA) approach is the management of 'functionality' to yield value for the customer. If a company seeks to reduce the costs of producing a product, then it must seek out costs that are unnecessary or items of the product that provide no functional value to the customer. In this case the first three (No cost can be removed if it compromises the quality of the product or its reliability, marketability is another issue that cannot be compromised and any activity that reduces the maintainability of the product increases the cost of ownership to the customer and can lower the value attached to the product) are issues of adding functionality to

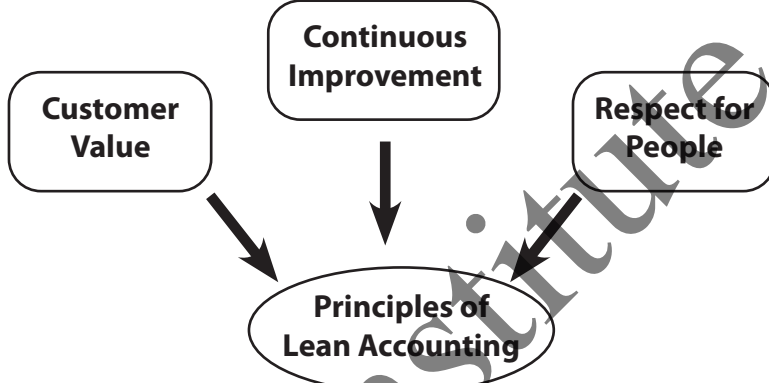
(iv)	(a)	<p>Value Analysis is a process of improving value for money in a product, service or company. It is a systematic approach to analyze, identify and reduce costs and/or improve performance. The focus of Value Analysis is to optimize value by eliminating or reducing unnecessary costs and improving effectiveness of resources. This is done by examining the functions that are performed, the processes and materials used, the costs associated and the overall performance of the system. Exchange value is the amount of money that can be exchanged for a given item or service and is not a part of Value Analysis.</p> <p>Thus A is the answer.</p>										
(v)	(c)											
(vi)	(b)	<p>Justification</p> <table style="width: 100%; border-collapse: collapse;"> <tr> <td style="width: 60%;">400 Units of Product B should take (× 4 hours)</td> <td style="text-align: right;">= 1600 hours</td> </tr> <tr> <td>But did take (active hours)</td> <td style="text-align: right;">= 1660 hours</td> </tr> <tr> <td>Efficiency variance in hours</td> <td style="text-align: right;">= 60 hours</td> </tr> <tr> <td>× standard rate per hour</td> <td style="text-align: right;">× 1.70</td> </tr> <tr> <td></td> <td style="text-align: right; border-top: 1px solid black; border-bottom: 3px double black;">102 (A)</td> </tr> </table>	400 Units of Product B should take (× 4 hours)	= 1600 hours	But did take (active hours)	= 1660 hours	Efficiency variance in hours	= 60 hours	× standard rate per hour	× 1.70		102 (A)
400 Units of Product B should take (× 4 hours)	= 1600 hours											
But did take (active hours)	= 1660 hours											
Efficiency variance in hours	= 60 hours											
× standard rate per hour	× 1.70											
	102 (A)											
(vii)	(a)	<p>Budgeted C/S ration = 30%</p> <p>Therefore, Budgeted Contribution = 30% × budgeted selling price = 30% × ₹ 300 = ₹ 90</p> <p>Sales Volume should have been = 500 units But was = 521 units</p> <p>Sales volume variance in units = 21 units (F) × Standard contribution per unit = × ₹ 90</p> <p>Sales volume contribution variance = ₹ 1,890 (F)</p>										

(viii)	(c)	Weeks worked per year = $52 - 4 = 48$
		Hours worked per year = $48 \times 40 \text{ hours} = 1920 \text{ hours}$
		Hours chargeable to clients = $1920 \times 90\% = 1728$
		Total expenses = ₹ 10,000 + ₹ 40,000 = ₹ 50,000
		Hourly rate = $\frac{50000}{1728} = ₹ 28.94$

SJC Institute

MTP Dec'23 (Set 1)

- (i) Which of the following is not a term normally used in value analysis?
- Resale value
 - Use value
 - Esteem value
 - Cost value
- (ii) DMIADV is a methodology associated with
- Pareto Analysis
 - PRAISE
 - Six Sigma
 - None of the above

(iii) XYZ Ltd. has the following alternative planned activity levels.

Level	E	F	G
Total cost (₹)	1,00,000	1,50,000	2,00,000
No. of units produced	5000	10000	15000

If fixed overhead remains constant, then fixed overhead cost per unit at Level E is:

- ₹ 20
 - ₹ 15
 - ₹13.33
 - ₹ 10
- (iv) A company has a breakeven point when sales are ₹ 3,20,000 and variable cost at that level of sales are ₹ 2,00,000. How much would contribution margin increase or decrease if variable expenses are dropped by ₹30,000?
- Increase by 27.5%
 - Increase by 9.375%
 - Decrease by 9.375%
 - Increase by 37.5%
- (v) H Group has two divisions, Division P and Division Q. Division P manufactures an item that is transferred to Division Q. The item has no external market and 6000 units produced are transferred internally each year. The costs of each division are as follows:

	Division P	Division Q
Variable Cost (₹)	100 per unit	120 per unit
Fixed cost each year (₹)	1,20,000	90,000

Head Office management decided that a transfer price should be set that provides a profit of ₹ 30,000 to Division P. What should be the transfer price per unit?

- a. ₹ 145
- b. ₹ 125
- c. ₹ 120
- d. ₹ 135

(vi) A company has the capacity of producing 80000 units and presently sells 20000 units at ₹ 100 each. The demand is sensitive to selling price and it has been observed that with every reduction of ₹ 10 in selling price the demand is doubled. What should be the target cost if the demand is doubled at full capacity and profit margin on sale is taken at 25%?

- a. ₹ 75
- b. ₹ 90
- c. ₹ 25
- d. ₹ 60

(vii) A factory can make only one of the three products X, Y or Z in a given production period. The following information is given:

Per Unit ₹	X	Y	Z
Selling Price	1500	1800	2000
Variable Cost	700	950	1000

Assume that there is no constraint on resource utilization or demand and similar resources are consumed by X, Y and Z. The opportunity cost of making one unit of Z is:

- a. ₹ 850
- b. ₹ 800
- c. ₹ 1,800
- d. ₹ 1,500

(viii) Twin Ltd. uses JIT and back flush accounting. It does not use a raw material stock control account. During September 2021, 10000 units were produced and sold. The standard cost per unit is ₹ 150 which includes materials of ₹ 60. During September 2021, ₹ 9,90,000 of conversion costs were incurred. The debit balance in cost of goods sold account for September 2021 is:

- a. ₹ 14,00,000
- b. ₹ 14,80,000
- c. ₹ 15,90,000
- d. ₹ 16,20,000

- (ix) The following figures are extracted from the books of a company:
- Budgeted O/H ₹ 10,000 (Fixed ₹ 6,000, Variable ₹ 4,000)
Budgeted Hours 2000
Actual O/H ₹ 10,400 (Fixed ₹ 6,100, Variable ₹ 4,300)
Actual Hours 2100
Variable O/H cost variance and Fixed O/H cost variance will be:
- 100 (A) and 200 (A)
 - 100 (F) and 200 (F)
 - 100 (A) and 200 (F)
 - 200 (A) and 100 (F)
- (x) Tableau is a –
- Business Intelligence Tool
 - Visualisation Tool
 - Both (a) and (b)
 - None of the above
- (xi) Which one of the following is a Key feature of SAS language?
- Capability of handling data analysis related to Operations Research and Project Management.
 - Capability of report formation with perfect graphs.
 - Capability to interact with multiple host systems
 - All the above
- (xii) A feasible solution of LPP –
- Must satisfy all the constraints simultaneously.
 - Need not satisfy all the constraints, only some of them.
 - Must be a corner point of the feasible region
 - All the above
- (xiii) A PERT activity has an optimistic time of 3 days, pessimistic time of 15 days and an expected time of 7 days. What is the most likely time of the activity?
- 10 days
 - 6 days
 - 5 days
 - None of the above

(xiv) MR is

- a. First order derivative of TC
- b. Second order derivative of TR
- c. First order derivative of TR
- d. Second order derivative of TC

(xv) The equations of the two lines of Regression are $4x + 3y + 7 = 0$ and $3x + 4y + 8 = 0$. The Coefficient of Correlation between x and y is –

- a. 1.25
- b. 0.25
- c. -0.75
- d. 0.92

Solution :

(i)	(ii)	(iii)	(iv)	(v)	(vi)	(vii)	(viii)	(ix)	(x)	(xi)	(xii)	(xiii)	(xiv)	(xv)
a	c	d	b	d	d	a	c	c	c	d	a	b	c	c

SJC Institute

June'23

1. Which one of the following is not a support activity of value chain?
 - a. Human Resource Management
 - b. Technological Development
 - c. Service
 - d. Infrastructure
2. Warranty period return of finished goods sold falls under the following quality cost:
 - a. Prevention
 - b. Appraisal
 - c. Internal failure
 - d. External failure
3. Target Costing is the answer to
 - a. Market Driven Prices
 - b. Seller's Market
 - c. No Profit Situation
 - d. None of the above
4. Producing more non bottleneck output
 - a. creates more inventory and increases throughput contribution
 - b. creates more inventory but does not increase throughput contribution
 - c. creates less pressure for the bottleneck workstations
 - d. allows for the maximisation of overall contribution
5. Which one of the following is not true for a Red ocean strategy and why?
 - a. Beat the competition
 - b. Exploit existing demand
 - c. Make the value cost trade-off
 - d. Break the value cost trade-off
6. SINT Ltd. determine its selling price by marking up the variable cost 50%. In addition, the company uses frequent selling price mark down to stimulate sales. The mark down average is 20%, what is the company's distribution margin ratio?
 - a. 16.67%
 - b. 18.50%

(vii) At ROXIN LTD., cost of personnel department has always been charged to production department based upon no. of employees. Recently opinion gathered from the department manager indicate that the no. of new hires might be better predictor or personnel cost. Total personnel department costs are ₹ 3,00,000.

Department	C	D	F
Number of Employees	40	300	160
Number of new hires	10	32	8

If the number of new hire is considered the cost driver, what amount of cost will be allocated to Department D?

- a. ₹ 2,00,000
- b. ₹ 1,92,000
- c. ₹ 1,50,000
- d. ₹ 1,30,000

(viii) BOSAN LTD. using added costing system provides the following information pertaining to Direct Labour for its product JUM for the month of May, 2023.

Standard Direct Labour Rate per hour ₹ 16
 Actual Direct Labour Rate per hour ₹ 14.50
 Labour Rate Variance ₹ 15,000 (Fav)
 Standard hours allowed for Actual production 8000 hours

How many Direct Labour hours were worked during month of May, 2023?

- a. 12,000 hours
- b. 11,000 hours
- c. 10,000 hours
- d. None of the above

Solution :

(i)	(ii)	(iii)	(iv)	(v)	(vi)	(vii)	(viii)
c	d	a	b	d	a	b	c

Postal Test Paper

- i. Which of the following is not a term normally used in value analysis?
- Resale value
 - Use value
 - Esteem value
 - Cost value
- ii. PRAISE stands for :
- Appreciating someone
 - Product, Recognition, Adoption, Invention, Solution & Evaporation
 - Problem Identification, Ranking, Analysis, Innovation, Solution & Evaluation
 - None of the above
- iii. Which of the following is not the quality parameter for service organizations?
- Consistency
 - Friendliness
 - Durability
 - Promptness
- iv. The break-even point of a manufacturing company is ₹1,60,000. Fixed cost is ₹48,000. Variable cost is ₹12 per unit. The PV ratio will be:
- 20%
 - 40%
 - 30%
 - 25%
- v. T Ltd. produces and sells a product. The company expects the following revenues and costs in 2022: Revenues (400 sets sold @ ₹ 600 per product) = ₹ 2,40,000
- Variable costs = ₹ 1,60,000
- Fixed costs = ₹ 50,000
- What amount of sales must T Ltd. have to earn a target net income of ₹63,000 if they have a tax rate of 30%?
- ₹ 4,20,000
 - ₹ 4,29,000
 - ₹ 3,00,000
 - ₹ 4,89,000

- vi. If project A has a net present value (NPV) of ₹ 30,00,000 and project B has an NPV of ₹ 50,00,000, what is the opportunity cost if project B is selected?
- ₹ 23,00,000
 - ₹ 30,00,000
 - ₹ 20,00,000
 - ₹ 50,00,000
- vii. Target costing is the answer to :
- Market driven prices
 - Sellers' market
 - No Profit situation
 - None of the above
- viii. Glasso, a manufacturer of large windows, is experiencing a bottleneck in its plant. Setup time at one of its workstations has been identified as the culprit. A manager has proposed a plan to reduce setup time at a cost of ₹ 7,20,000. The change will result in 800 additional windows. The selling price per window is ₹ 18,000, direct labour costs are ₹ 3000 per window, and the cost of direct materials is ₹ 7,000 per window. Assume all units produced can be sold. The change will result in an increase in the throughput contribution of _____.
- ₹ 64,00,000
 - ₹ 88,00,000
 - ₹ 56,80,000
 - ₹ 1,44,00,000

Solution :

(i)	(ii)	(iii)	(iv)	(v)	(vi)	(vii)	(viii)
a	c	c	c	a	b	a	b

Dec'23

- (i) Down time due to defect in quality in an example of
- Internal failure cost
 - Prevention cost
 - Appraisal cost
 - External failure cost
- (ii) Which one of the important pillars of Strategic Cost Management determines the company's comparative position in the Industry in terms of performance?
- Cost drivers Analysis
 - Value chain Analysis
 - Strategic positioning analysis
 - Competitive value analysis
- (iii) A production of ZON Ltd. has the capacity to produce either 4000 units of A, or 3500 units of B or 5000 units of C. Only one product can be made in a production period. The contributions per unit of A, B and C are ₹ 10, ₹ 11 and ₹ 8 respectively. The opportunity cost of A would be :
- ₹ 44,000
 - ₹ 38,000
 - ₹ 50,000
 - ₹ 40,000
- (iv) ROBINSON Ltd., a manufacturing company has a break even point, when sales are ₹ 10 lakh and fixed costs of ₹ 4 lakh. To realize profits of ₹ 2 lakhs from sales of 3,00,000 units, the selling price per unit will be -
- ₹ 6
 - ₹ 5
 - ₹ 4
 - ₹ 2
- (v) AMON Ltd. plans to introduce a new product ZOS and is using Target cost approach. The selling price of product ZOS is set at ₹ 120 for each unit and sales revenue for the coming year is expected to be ₹ 9,60,000. The company requires a return of 15% on the coming year on its investment of ₹ 20 lakh. What is the Target Cost per unit for the coming year?
- ₹ 90.00
 - ₹ 85.00

- c. ₹ 82.50
 - d. 80.50
- (vi) The highest negative opportunity cost value in an unused cell of a Transportation Matrix is chosen to improve the current solution because -
- a. It represents maximum possible cost reduction per unit
 - b. It ensures no violation of Rim Condition
 - c. It represents per unit cost improvement
 - d. Either one of the above
- (vii) RRS, a manufacturer of large windows, is experiencing a bottleneck in its plant. Setup time at one of its workstations has been identified as the culprit. A manager has proposed a plan to reduce setup time at a cost of ₹ 7,20,000. The change will result in 800 additional windows. The selling price per window is ₹ 18,000, direct labour costs are ₹ 3,000 per window and the costs of direct materials is ₹ 7,000 per window. Assume all units produced can be sold. The change will result in an increase in the throughput contribution of ____
- a. ₹ 64,00,000
 - b. ₹ 88,00,000
 - c. ₹ 56,80,000
 - d. ₹ 1,44,00,000
- (viii) An employee of ROB Ltd. took 200 minutes to complete the first set up on a new machine. Using a 90% incremental unit time learning model indicates that the second set up on the new machine is expected to take -
- a. 160 minutes
 - b. 120 minutes
 - c. 100 minutes
 - d. 80 minutes
- (ix) The drive-up window of a fast food operation was being studied using simulation for a variety of operating characteristics. As part of the study, data was collected on Order Processing Time as given in the following table. Using the first two digits of the Random Numbers, determine the processing time that would be used to simulate the fifth sample.

Processing time (Minutes)	1	2	3	4
Probability	0.30	0.45	0.20	0.05

Customer	1	2	3	4	5	6	7	8	9
Random No.	1048	2236	2413	4216	3757	1501	4657	4836	9309

- a. 2 minutes

- b. 4 minutes
- c. 1 minute
- d. 3 minutes

- (x) A Co. producing output X and Y uses standard costing. The standard overhead contents of each product is :

X : ₹ 3 per unit and Y : ₹ 2.25 per unit.

The budgeted overhead is ₹ 860 and budgeted time is 3440 hours.

Actual Output :

X 200 units and Y 100 units.

Actual time : 3200 hours

Actual overhead : ₹ 875. Compute Overhead Volume Variance.

- a. ₹ 35 (A)
- b. ₹ 35 (A)
- c. ₹ 25 (A)
- d. ₹ 15 (A)

- (xi) The value of the game of

Player A	Player B	
	B1	B2
A1	4	6
A2	-10	10

is _____. Fill in the above.

- a. 4
- b. 6
- c. 8
- d. None of the above

- (xii) The slack time of tail event of activity Z of a project is 2 days. If the total Float and free float of the activity Z are 10 days and 7 days respectively, the Independent float of activity Z will be:

- a. 5 days
- b. 6 days
- c. 7 days
- d. 2 days

- (xiii) Which of the following has no relation to business intelligence?
- A set of business analytics solutions to retrieve, analyse and transform data into useful business sights
 - Visualisation Tools are primarily BI Tools
 - ABS Glue is a tool used for the purpose of Business Intelligence
 - Embedded Analytics is an important part of any Business Intelligence Tool
- (xiv) Which of the following is/ are the Financial analytics tools?
- Hyper Anna
 - Jedox
 - Net Suite
 - All of the above
- (xv) Which one of the following is not a part of qualitative type of forecasting techniques?
- Survey Technique
 - Barometric Technique
 - Exponential Smoothing
 - Delphi Technique

Solution :

(i)	(ii)	(iii)	(iv)	(v)	(vi)	(vii)	(viii)	(ix)	(x)	(xi)	(xii)	(xiii)	(xiv)	(xv)
a	c	d	b	c	a	b	a	a	a	a	a	c	d	c



FINAL EXAMINATION
MODEL QUESTION PAPER
PAPER – 16

SET - 1
TERM – JUNE 2024
SYLLABUS 2022

STRATEGIC COST MANAGEMENT

Time Allowed: 3 Hours

Full Marks: 100

The figures in the margin on the right side indicate full marks.

SECTION – A (Compulsory)

1. Choose the correct option:

[15 x 2=30]

- (i) Which of the following is not a secondary activity of Value Chain?
- Procurement
 - Human Resource Development
 - Service
 - Technology Development
- (ii) The break-even point of a manufacturing company is ₹1,60,000. Fixed cost is ₹48,000. Variable cost is ₹12 per unit. The PV ratio will be:
- 20%
 - 40%
 - 30%
 - 25%
- (iii) The higher the actual hours worked _____.
- The lower the capacity usage ratio.
 - The higher the capacity usage ratio.
 - The lower the capacity utilization ratio.
 - The higher the capacity utilization ratio.
- (iv) The Tech Company has fixed costs of ₹ 400,000 and variable costs are 75% of the selling price. To realize profits of ₹ 100,000 from sales of 5,00,000 units, the selling price per unit _____.
- must be ₹1.00
 - must be ₹4.80
 - must be ₹4.00
 - cannot be determined
- (v) X Ltd. has 1000 units of an obsolete item which are carried in inventory at the original price of ₹ 50,000. If these items are reworked for ₹ 20,000, they can be sold for ₹ 36,000. Alternatively, they can be sold as a scrap for ₹ 6,000 in the market. In a decision model used to analyse the reworking proposal, the opportunity cost should be taken as _____.



FINAL EXAMINATION
MODEL QUESTION PAPER
PAPER – 16

SET - 1
TERM – JUNE 2024
SYLLABUS 2022

STRATEGIC COST MANAGEMENT

- a) ₹ 16,000
- b) ₹ 6,000
- c) ₹ 30,000
- d) ₹ 20,000

(vi) A Ltd. Plans to introduce a new product and issuing the target cost approach. Projected sales revenue is ₹ 90,00,000 (₹45 per unit) and target costs are ₹ 64,00,000. What is the desired profit per unit?

- a) ₹ 13
- b) ₹ 17
- c) ₹ 32
- d) ₹ 10

(vii) AP Products sells product A at a selling price of ₹40 per unit. AP's cost per unit based on the full capacity of 5,00,000 units is as follows:

Direct material	6
Direct Labour	3
Indirect Manufacturing Expense 60% of which is fixed	10
Total	19

A one-time only special order offering to buy 50,000 units was received from an overseas distributor. The only other costs that would be incurred on this order would be ₹ 4 per unit for shipping. AP has sufficient existing capacity to manufacture the additional units. In negotiating a price for the special order, AP should consider that the minimum selling price per unit should be _____.

- a) ₹ 17
- b) ₹ 19
- c) ₹ 21
- d) ₹ 23

(viii) Ankit Ltd., operates throughput accounting system. The details of product A per unit are as under:

Selling Price: ₹ 75

Material Cost: ₹ 30

Conversion Cost: ₹20

Time to bottleneck resources: 10 minutes

What is the throughput contribution per bottleneck resource per hour?

- a) ₹ 270
- b) ₹ 150
- c) ₹ 120
- d) ₹ 90



FINAL EXAMINATION
MODEL QUESTION PAPER
PAPER – 16

SET - 1
TERM – JUNE 2024
SYLLABUS 2022

STRATEGIC COST MANAGEMENT

- (ix) Efficiency Ratio is _____.
- Available working days ÷ Budgeted working days × 100
 - Budgeted hours ÷ Maximum hours in budgeted period × 100
 - Standard hours ÷ Actual hours × 100
 - None of the above
- (x) Which of the following statement is incorrect?
- Microsoft Excel is most popular among all the available spreadsheets.
 - Zoho Analytics is a tool used for Financial Data analysis.
 - Visualisation Tools are the Reporting Tools.
 - None of the above.
- (xi) Prescriptive Analytics is very important because –
- It tells about the action to be taken.
 - It tells about what is likely to happen.
 - It tells about how something has happened.
 - It tells about what has happened.
- (xii) The information relating to the direct material cost of a company is as follows:
- Standard price per unit ₹7.20
Actual quantity purchased in units 1600
Standard quantity allowed for actual production in units 1450
Material price variance on purchase (Favourable) ₹480 What is the actual purchase price per unit?
- ₹ 7.50
 - ₹ 6.40
 - ₹ 6.5
 - ₹ 6.90
- (xiii) The Normal duration and Normal cost of an activity are respectively 10 days and ₹ 350. The cost slope is ₹ 75 per day. If the Crash duration is 8 days then what is the Crash cost of the activity?
- ₹ 400
 - ₹ 500
 - ₹ 600
 - ₹ 650
- (xiv) Optimization is the method of finding _____.
- The maximum point
 - The minimum point
 - The critical point
 - All of the above



FINAL EXAMINATION
MODEL QUESTION PAPER
PAPER – 16

SET - 1
TERM – JUNE 2024
SYLLABUS 2022

STRATEGIC COST MANAGEMENT

- (xv) The actual demand for a period is 100 units. But forecast demand was 90 units. The forecast error is –
- 10
 - 10
 - 5
 - None of the above

SECTION – B

(Answer any 5 questions out of 7 questions given. Each question carries 14 marks.)

[5 x 14 = 70]

2. A manufacturing company currently operating at 80% capacity has received an export order from Middle East, which will utilise 40% of the capacity of the factory. The order has to be either taken in full and executed at 10% below the current domestic prices or rejected totally. The current sales and cost data are given below: [14]

Sales	₹ 16.00 lakhs
Direct Material	₹ 5.80 lakhs
Direct Labour	₹ 2.40 lakhs
Variable Overheads	₹ 0.60 lakhs
Fixed Overheads	₹ 5.20 lakhs

The following alternatives are available to the management:

- Continue with domestic sales and reject the export order.
- Accept the export order and allow the domestic market to starve to the extent of excess of demand.
- Increase capacity so as to accept the export order and maintain the domestic demand by:
 - Purchasing additional plant and increasing 10% capacity and thereby increasing fixed overheads by ₹ 65,000, and
 - Working overtime at one and half time the normal rate to meet balance of the required capacity.

Required: Evaluate each of the above alternatives and suggest the best one.

3. (a) Division A is a profit centre which produces three products X, Y and Z. Each product has an external market. The details are as follows:

	X	Y	Z
External market price per unit (₹)	48	46	40
Variable cost of production in division A (₹)	33	24	28
Labour hours required per unit in division A	3	4	2

Product Y can be transferred to Division B, but the maximum quantity that might be required for transfer is 300 units of Y.



FINAL EXAMINATION
MODEL QUESTION PAPER
PAPER – 16

SET - 1
TERM – JUNE 2024
SYLLABUS 2022

STRATEGIC COST MANAGEMENT

	X	Y	Z
The maximum external sales are:	800 Units	500 Units	300 Units

Instead of receiving transfers of Product Y from Division A, Division B could buy similar product in the open market at a slightly cheaper price of ₹ 45 per unit.

Compute the transfer price for each unit, for 300 units of Y, if the total labour hours available in Division A are?

- (a) 3800 hours
(b) 5600 hours. [7]

- (b) A company has estimated the unit variable cost of a Product to be ₹ 10, and the selling price is ₹ 15 per unit. Budgeted sales for the year are 20,000 units. Estimated fixed costs are as follows:

Fixed Cost p.a.(₹)	50,000	60,000	70,000	80,000	90,000
Probability	0.1	0.3	0.3	0.2	0.1

Assess the probability that the company will equal or exceed its target profit of ₹ 25,000 for the year? [7]

4. (a) T Ltd, produces a product which passes through two processes - cutting and finishing. The following information is provided: [7]

	Cutting	Finishing
Hours available per annum	50,000	60,000
Hours needed per unit of product	5	12
Fixed operating costs per annum excluding direct material (₹)	10,00,000	10,00,000

The selling price of the product is ₹ 1,000 per unit and the only variable cost per unit is direct material, which costs ₹ 400 per unit. There is demand for all units produced.

Evaluate each of the following proposals independent of each other:

- (i) An outside agency is willing to do the finishing operation of any number of units between 5,000 and 7,000 at ₹ 400 per unit.
(ii) Another outside agency is willing to do the cutting operation of 2,000 units at ₹ 200 per unit
(iii) Additional equipment for cutting can be bought for ₹ 10,00,000 to increase the cutting facility by 50,000 hours, with annual fixed costs increased by ₹ 2 lakhs.
- (b) Discuss the significance of lean accounting. [7]

5. Compute the missing data indicated by the Question marks from the following: [14]

	Product 'R'	Product 'S'
Sales quantity		
Std.(units)	?	400
Actual (Units)	500	?
Price (Unit)		
Standard	₹ 12	₹ 15
Actual	₹ 15	₹ 20
Sales price variance	?	?



FINAL EXAMINATION
MODEL QUESTION PAPER
PAPER – 16

SET - 1
TERM – JUNE 2024
SYLLABUS 2022

STRATEGIC COST MANAGEMENT

Sales volume variance	₹ 1,200 F	?
Sales value variance	?	?

Sales mix variance for both the products together was ₹ 450 F. 'F' denotes Favorable.

6. (a) The past data of demand per week (in '00 kgs.) of a confectionery item is given below –

Demand/Week	0	5	10	15	20	25
Frequency	2	11	8	21	5	3

Using the sequence of random numbers – 35, 52, 13, 90, 23, 73, 34, 57, 35, 83, 94, 56, 67, 66 generate the demand for the next 10 weeks. Also determine the average demand per week

[7]

- (b) A retired person has plans to invest in shares. He has been suggested by one of his friends who plays in the share market to invest in two shares A and B which gives dividends @ 12% and 4% p.a. respectively. For an investment of ₹ 1, the growth in the market value of the shares A and B are respectively 10 paise and 40 paise in one year. The retired person wants to invest such that the dividend income is at least ₹ 600 p.a. and the growth of initial investment in one year is at least ₹ 1000.

- (i) Formulate it as a Linear Programming Problem.
(ii) Write its Dual.

[7]

7. (a) The following table gives data on normal time & cost as well as crash time & cost for a project.

You need to draw the Network diagram and identify the Critical Path.

Also compute the Normal duration of the project and the corresponding Total Cost associated with it.

Crash the relevant activities systematically and determine the optimum completion time of the project. Also determine the corresponding cost when it is given that the Indirect Cost is ₹100 per day.

[7]

Activity	Normal		Crash	
	Time (days)	Cost (₹)	Time (days)	Cost (₹)
1—2	6	600	4	1,000
1—3	4	600	2	2,000
2—4	5	500	3	1,500
2—5	3	450	1	650
3—4	6	900	4	2,000
4—6	8	800	4	3,000
5—6	4	400	2	1,000
6—7	3	450	2	800

- (b) A firm received an order to make and supply eight units of standard product which involves intricate labour operations. The first unit was made in 10 hours. It is understood that this type of operation is subject to an 80% learning rate. The workers are getting wages at the rate of ₹12 per hour.

- (i) What is the total time and labour cost required to execute the above order?
(ii) If a repeat order of 24 units is also received from the same customer, calculate the labour cost necessary for the second order.

[7]



FINAL EXAMINATION
MODEL QUESTION PAPER
PAPER – 16

SET - 1
TERM – JUNE 2024
SYLLABUS 2022

STRATEGIC COST MANAGEMENT

8. (a) Is the following two persons, zero – sum game stable? (the payoff is for player A). solve the game:

Player B

Player A	5	-10	9	0
	6	7	8	1
	8	7	15	1
	3	4	-1	4

[7]

- (b) Calculate the Seasonal Indices for the following quarterly data in certain units. Appropriate method for finding the Indices has to be decided by you with due explanation.

Year	1st Quarter	2nd Quarter	3rd Quarter	4th Quarter
2020	39	21	52	81
2021	45	23	63	76
2022	44	26	69	75
2023	53	23	64	84

[7]